

DRIVE END

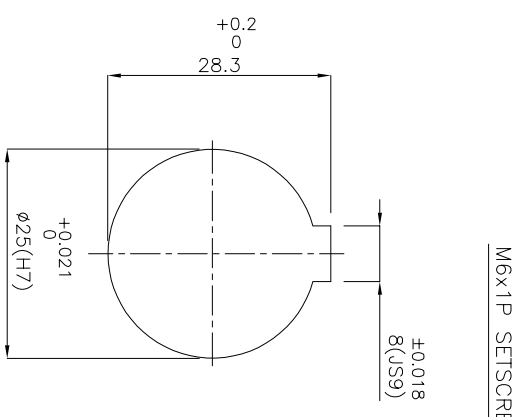

DRIVEN END

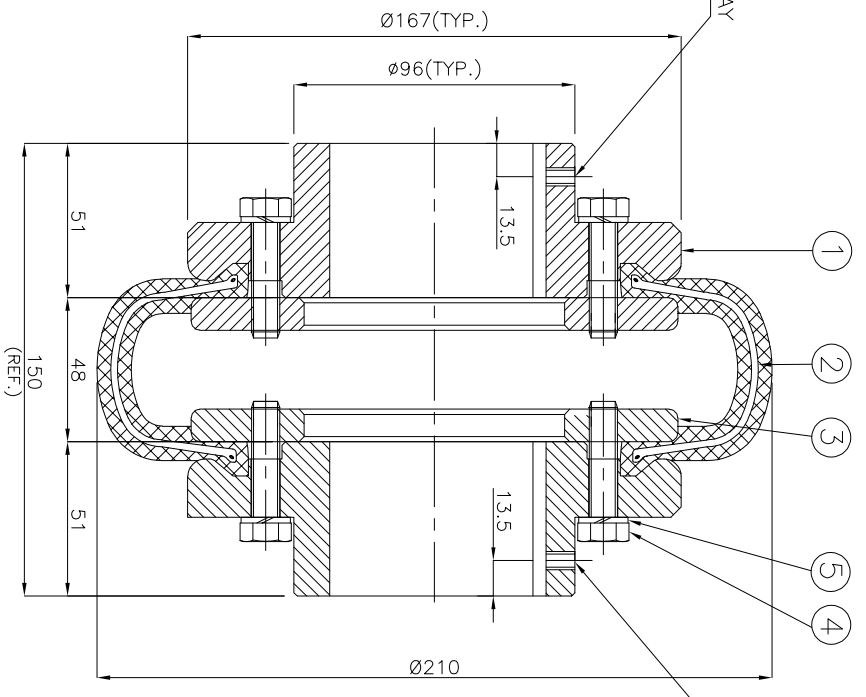
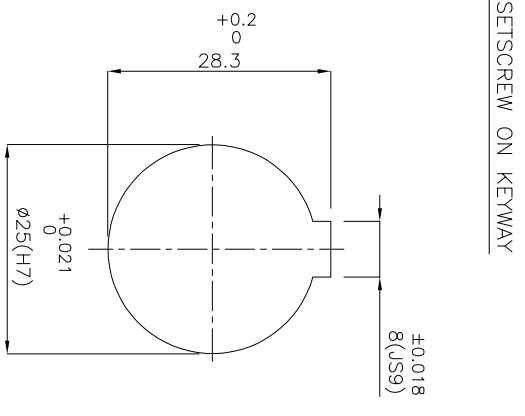

APPLICATION DETAILS

APPLICATION	-
RATED POWER	-
RATED SPEED	-
RATED TORQUE	-
A.S.F.	-

COUPLING SPECIFICATIONS

COUPLING RATING	3.93 kW @ 100 RPM
RATED TORQUE	0.375 kNm.
PEAK TORQUE	0.750 kNm.
MAX. SPEED	3100 rpm.
MAX. BORE	63 mm
WEIGHT(Approx.)	10.5 Kg
INERTIA (WK ²)	0.040 Kgm ²

COUPLING HUBS DYNAMICALLY BALANCED TO GR.6.3 AS PER ISO: 1940-1.

MAX. MISALIGNMENTS

AXIAL DEFLECTION	±2.6 mm.
ANGULAR DEFLECTION	2'
RADIAL DEFLECTION	2.1 mm

SR NO	DESCRIPTION	MATERIAL	QTY.
5	SPRING WASHER	SPRING STEEL	12
4	HEX HEAD BOLT	HIGH TENSILE STEEL	12
3	CLAMPING RING	M.S. IS 2062	2
2	TYRE	NATURAL RUBBER	1
1	HUB	CI-S-210 GR.FG 260	2

TITLE: **T-8 B/----- CPLG.**

CUSTOMER NAME:

MATERIAL: REFER TABLE

AUTHORITY/INITIALS	SIGN	DATE
DRAWN	-	-
CHECKED	-	-
APPROVED	-	-

SCALE: NTS REF. No.:



RATHI TRANSPOWER PVT LTD
PUNE 411006

DRG. No.:

This drawing / information / design is the property of Rathi Transpower Pvt. Ltd. It is confidential & must not be made public or copied without prior written authorization & is subjected to recall at any time. Acceptance of this drawing constitutes full agreement with these conditions