

**DRIVE SIDE**

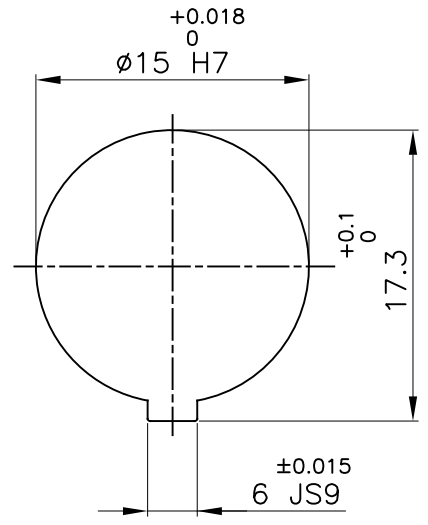

**DRIVEN SIDE**

**APPLICATION DETAILS**

APPLICATION	-
RATED POWER	- KW
RATED SPEED	- RPM.
RATED TORQUE	- Nm
A.S.F.	-

**COUPLING CAPACITY**

COUPLING RATING	6.96 KW AT 100RPM.
RATED TORQUE	667 Nm
MAX. BORE TYPE-II	62mm
WEIGHT (APPROX)	5.2kg
INERTIA (WK <sup>2</sup> )	9.6X10 <sup>-3</sup> kg-m <sup>2</sup>

**MAX. MISALIGNMENT**

AXIAL	±3.0mm
ANGULAR	1°
PARALLE	0.35mm

3	HUB-II	C.I. IS:210 FG 260	1
2	SPIDER	POLYURETHANE (LIGHT LVORY)	1
1	HUB-II	C.I. IS:210 FG 260	1
SR NO	DESCRIPTION	MATERIAL	QTY.

REV.	DMRN NO.	DESCRIPTION	REV. BY	APPD. BY	DATE

TITLE: **RRJ-48 II/II /-----**  
**CPLG.**

MATERIAL: **REFER TABLE**

CUSTOMER NAME: -

AUTHORITY	INITIALS	SIGN	DATE
DRAWN	-	-	-
CHECKED	-	-	-
APPROVED	-	-	-

SCALE: NTS REF. No.: -

**Lovejoy** RATHI TRANSPower PVT LTD PUNE 411014 DRG. No.: -----/-

This drawing / information / design is the property of Rathi Transpower Pvt. Ltd. It is confidential & must not be made public or copied without prior written authorization & is subjected to recall at any time. Acceptance of this drawing constitutes full agreement with these conditions