

J I H G F E D C B A

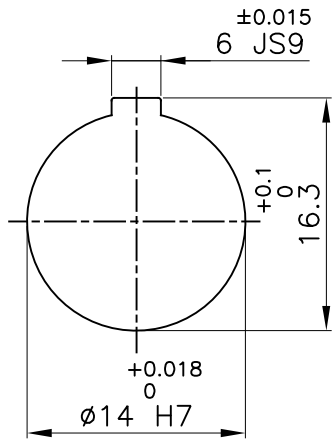

DRIVE SIDE

M5X0.8P TAPPED HOLE FOR SET SCREW ON KEYWAY.

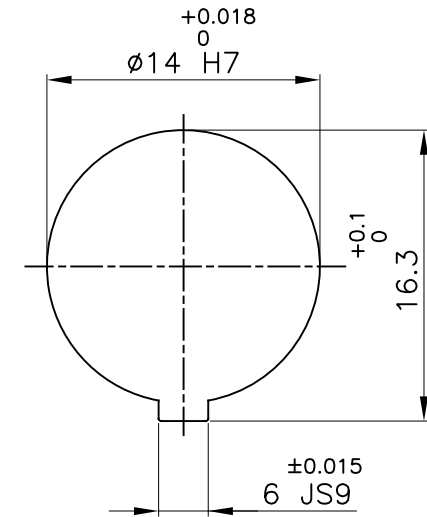
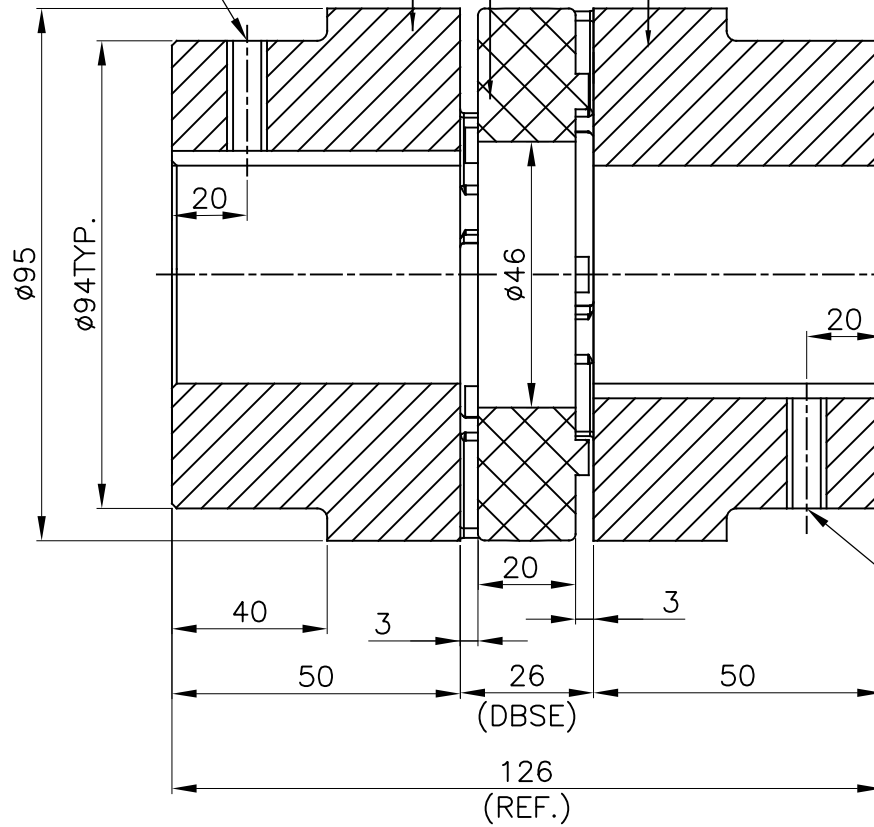

DRIVEN SIDE

M5X0.8P TAPPED HOLE FOR SET SCREW ON KEYWAY.

APPLICATION DETAILS

APPLICATION	-
RATED POWER	- KW
RATED SPEED	- RPM.
RATED TORQUE	- Nm
A.S.F.	-

COUPLING CAPACITY

COUPLING RATING	2.65 KW AT 100RPM.
RATED TORQUE	253 Nm
MAX. BORE TYPE-I	55mm
WEIGHT (APPROX)	3.8kg
INERTIA (WK ²)	5.9X10 ⁻³ kg-m ²

MAX. MISALIGNMENT

AXIAL	±2.3mm
ANGULAR	0.90°
PARALLE	0.30mm

3	HUB-II	C.I. IS:210 FG 260	1
2	SPIDER	POLYURETHANE (GRAY)	1
1	HUB-II	C.I. IS:210 FG 260	1
SR NO	DESCRIPTION	MATERIAL	QTY.

REV.	DMRN NO.	DESCRIPTION	REV. BY	APPD. BY	DATE

TITLE: **RRJ-42 II/II /-----**
CPLG.

MATERIAL: **REFER TABLE**

CUSTOMER NAME: _____

AUTHORITY	INITIALS	SIGN	DATE
DRAWN	-	-	-
CHECKED	-	-	-
APPROVED	-	-	-

SCALE: NTS REF. No.: _____

Lovejoy RATHI TRANSPower PVT LTD PUNE 411014 DRG. No.: _____/-

This drawing / information / design is the property of Rathi Transpower Pvt. Ltd. It is confidential & must not be made public or copied without prior written authorization & is subjected to recall at any time. Acceptance of this drawing constitutes full agreement with these conditions