

**DRIVE SIDE**

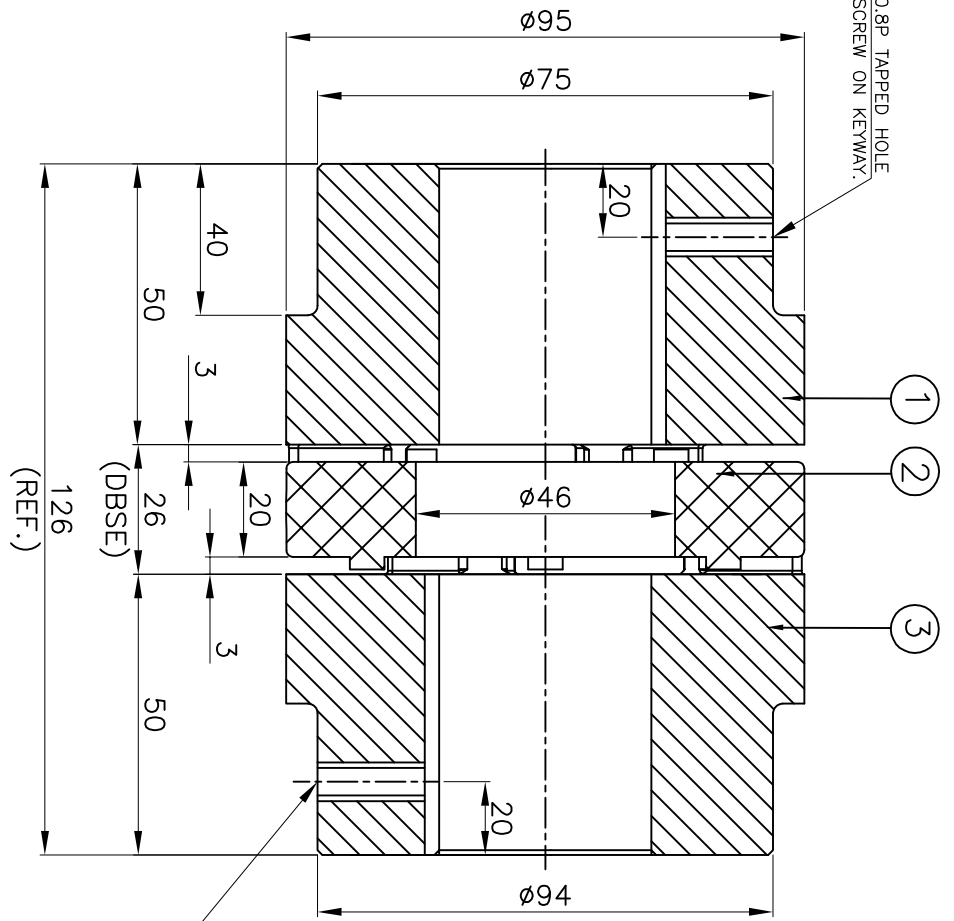

**DRIVEN SIDE**

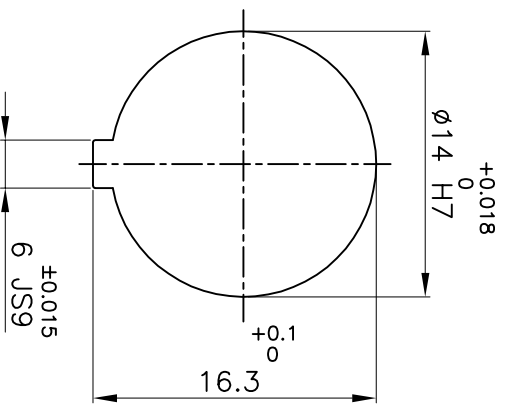

(REF.)

MSX0.8P TAPPED HOLE  
FOR SET SCREW ON KEYWAY.

**APPLICATION DETAILS**

APPLICATION	-
RATED POWER	- KW
RATED SPEED	- RPM
RATED TORQUE	- Nm
A.S.F.	-

**COUPLING CAPACITY**

COUPLING RATING	2.65KW AT 100RPM.
RATED TORQUE	253Nm
MAX. BORE TYPE-I & II	45 & 55mm
WEIGHT (APPROX)	3.8kg
INERTIA (WK <sup>2</sup> )	5.9X10 <sup>-3</sup> kg-m <sup>2</sup>

**MAX. MISALIGNMENT**

AXIAL	±2.3mm
ANGULAR	0.90°
PARALLEL	0.30mm

S/N	SR NO	DESCRIPTION	MATERIAL	QTY.
3	HUB-II	C.I. IS:210 FG 260		1
2	SPIDER	POLYURETHANE (GRAY)		1
1	HUB-I	C.I. IS:210 FG 260		1

TITLE: **RRJ-42 I/II /-----**  
**CPLG.**  
 MATERIAL: **REFER TABLE**  
 CUSTOMER NAME: **---**

**RATHI TRANSPOWER PVT LTD**  
 PUNE 411014  
 DRG. No.: -----/---  
 3 EN-F-112