

IF IN DOUBT, PLEASE ASK

J I H G F E D C B A

DO NOT SCALE ALL DIMENSIONS ARE IN mm

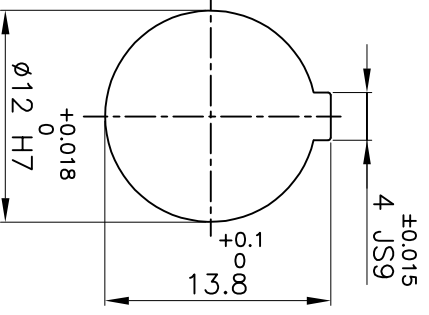

DRIVE SIDE

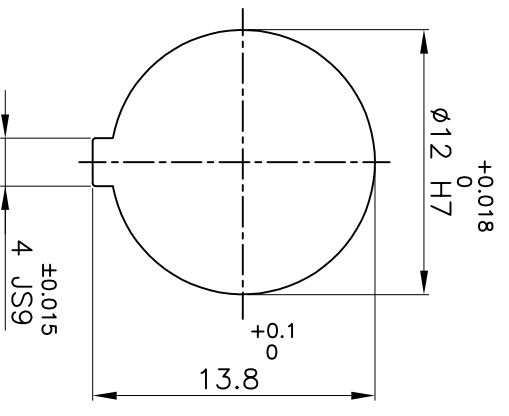
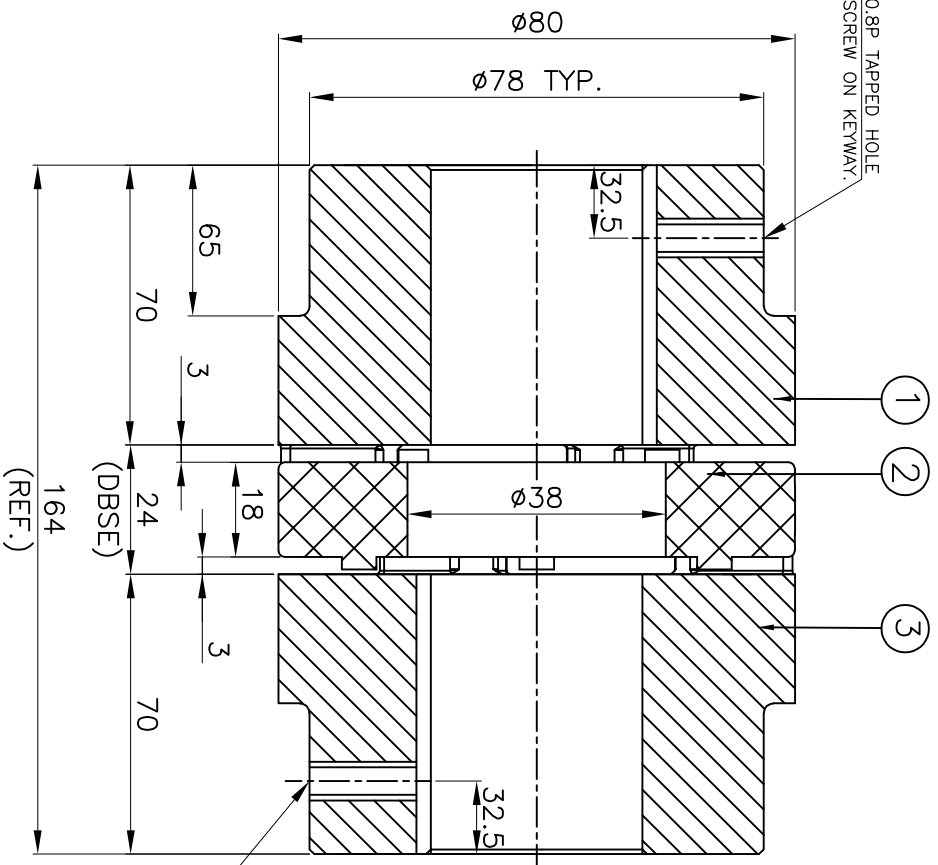

DRIVEN SIDE

MSX0.8P TAPPED HOLE FOR SET SCREW ON KEYWAY.

(REF.)

(DBSE)

164

70

3

18

24

70

3

65

70

3

32.5

32.5

Ø38

Ø80

Ø78 TYP.

MSX0.8P TAPPED HOLE FOR SET SCREW ON KEYWAY.

1 2 3

164

70

3

18

24

70

3

65

70

3

32.5

32.5

Ø38

Ø80

Ø78 TYP.

MSX0.8P TAPPED HOLE FOR SET SCREW ON KEYWAY.

1 2 3

164

70

3

18

24

70

3

65

70

3

32.5

32.5

Ø38

Ø80

Ø78 TYP.

MSX0.8P TAPPED HOLE FOR SET SCREW ON KEYWAY.

1 2 3

164

70

3

18

24

70

3

65

70

3

32.5

32.5

Ø38

Ø80

Ø78 TYP.

MSX0.8P TAPPED HOLE FOR SET SCREW ON KEYWAY.

1 2 3

164

70

3

18

24

70

3

65

70

3

32.5

32.5

Ø38

Ø80

Ø78 TYP.

MSX0.8P TAPPED HOLE FOR SET SCREW ON KEYWAY.

1 2 3

164

70

3

18

24

70

3

65

70

3

32.5

32.5

Ø38

Ø80

Ø78 TYP.

MSX0.8P TAPPED HOLE FOR SET SCREW ON KEYWAY.

1 2 3

164

70

3

18

24

70

3

65

70

3

32.5

32.5

Ø38

Ø80

Ø78 TYP.

MSX0.8P TAPPED HOLE FOR SET SCREW ON KEYWAY.

1 2 3

164

70

3

18

24

70

3

65

70

3

32.5

32.5

Ø38

Ø80

Ø78 TYP.

MSX0.8P TAPPED HOLE FOR SET SCREW ON KEYWAY.

1 2 3

164

70

3

18

24

70

3

65

70

3

32.5

32.5

Ø38

Ø80

Ø78 TYP.

MSX0.8P TAPPED HOLE FOR SET SCREW ON KEYWAY.

1 2 3

164

70

3

18

24

70

3

65

70

3

32.5

32.5

Ø38

Ø80

Ø78 TYP.

MSX0.8P TAPPED HOLE FOR SET SCREW ON KEYWAY.

1 2 3

164

70

3

18

24

70

3

65

70

3

32.5

32.5

Ø38

Ø80

Ø78 TYP.

MSX0.8P TAPPED HOLE FOR SET SCREW ON KEYWAY.

1 2 3

164

70

3

18

24

70

3

65

70

3

32.5

32.5

Ø38

Ø80

Ø78 TYP.

MSX0.8P TAPPED HOLE FOR SET SCREW ON KEYWAY.

1 2 3

164

70

3

18

24

70

3

65

70

3

32.5

32.5

Ø38

Ø80

Ø78 TYP.

MSX0.8P TAPPED HOLE FOR SET SCREW ON KEYWAY.

1 2 3

164

70

3

18

24

70

3

65

70

3

32.5

32.5

Ø38

Ø80

Ø78 TYP.

MSX0.8P TAPPED HOLE FOR SET SCREW ON KEYWAY.

1 2 3

164

70

3

18

24

70

3

65

70

3

32.5

32.5

Ø38

Ø80

Ø78 TYP.

MSX0.8P TAPPED HOLE FOR SET SCREW ON KEYWAY.

1 2 3

164

70

3

18

24

70

3

65

70

3

32.5

32.5

Ø38

Ø80

Ø78 TYP.

MSX0.8P TAPPED HOLE FOR SET SCREW ON KEYWAY.

1 2 3

164

70

3

18

24

70

3

65

70

3

32.5

32.5

Ø38

Ø80