

J I H G F E D C B A

8

7

6

5

4

3

2

1

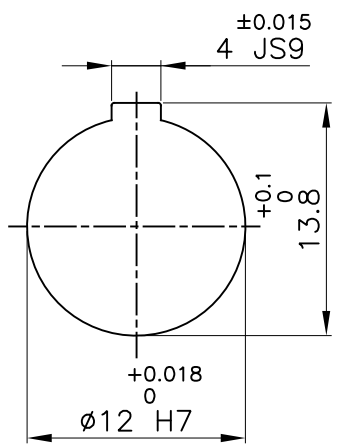

DRIVE SIDE

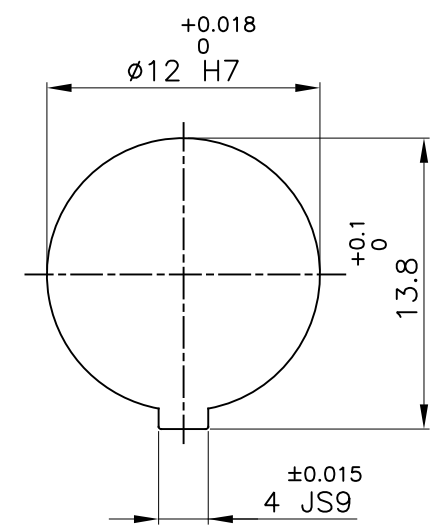
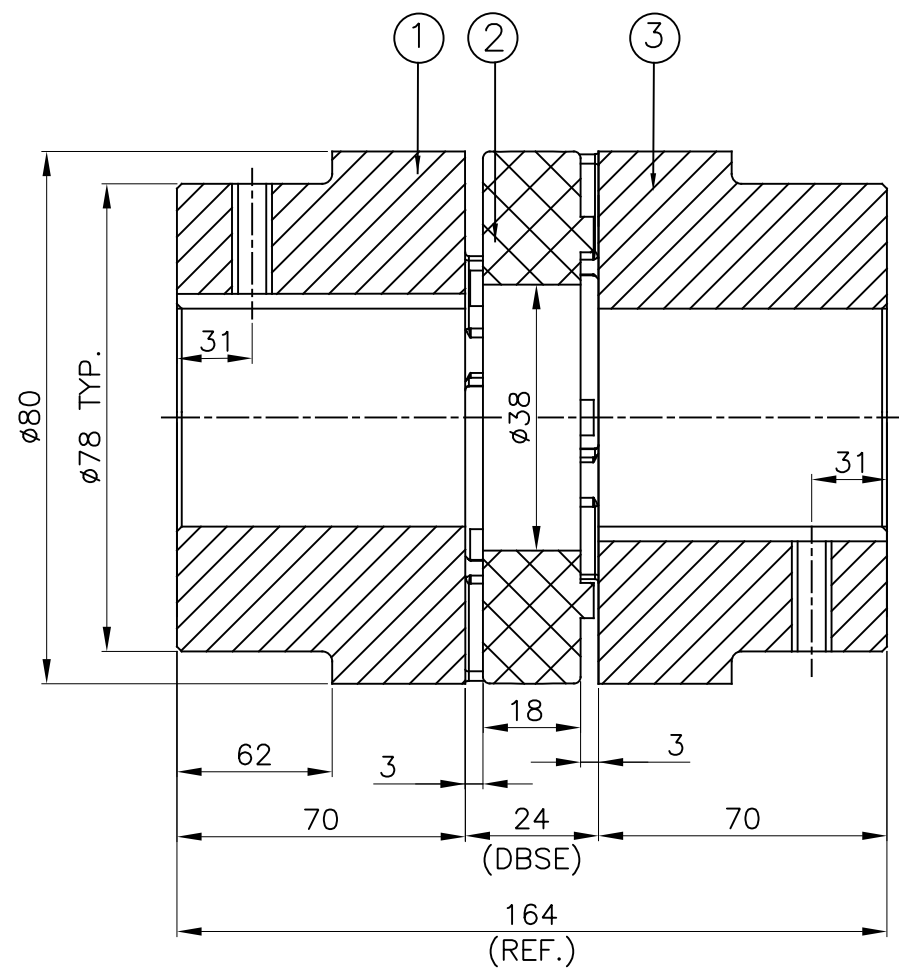

DRIVEN SIDE

APPLICATION DETAILS

APPLICATION	-
RATED POWER	- KW
RATED SPEED	- RPM.
RATED TORQUE	- Nm
A.S.F.	-

COUPLING CAPACITY

COUPLING RATING	3.47KW AT 100RPM.
RATED TORQUE	332Nm
MAX. BORE TYPE-III	48mm
WEIGHT (APPROX)	3.60kg
INERTIA (WK ²)	3.72X10 ⁻³ kg-m ²

MAX. MISALIGNMENT

AXIAL	±2.2mm
ANGULAR	0.90°
PARALLE	0.25mm

3	HUB-I	C.I IS:210	1
2	SPIDER	POLYURETHANE (BLUE)	1
1	HUB-I	C.I IS:210	1
SR NO	DESCRIPTION	MATERIAL	QTY.

REV.	DMRN NO.	DESCRIPTION	REV. BY	APPD. BY	DATE

TITLE: **RRJ-38 III/III /-----**
CPLG.

MATERIAL: **REFER TABLE**

CUSTOMER NAME: -

AUTHORITY	INITIALS	SIGN	DATE
DRAWN	-	-	-
CHECKED	-	-	-
APPROVED	-	-	-

SCALE: NTS REF. No.: -----

Lovejoy RATHI TRANSPower PVT LTD PUNE 411006 DRG. No.: -----/-

This drawing / information / design is the property of Rathi Transpower Pvt. Ltd. It is confidential & must not be made public or copied without prior written authorization & is subjected to recall at any time. Acceptance of this drawing constitutes full agreement with these conditions