

DRIVE SIDE

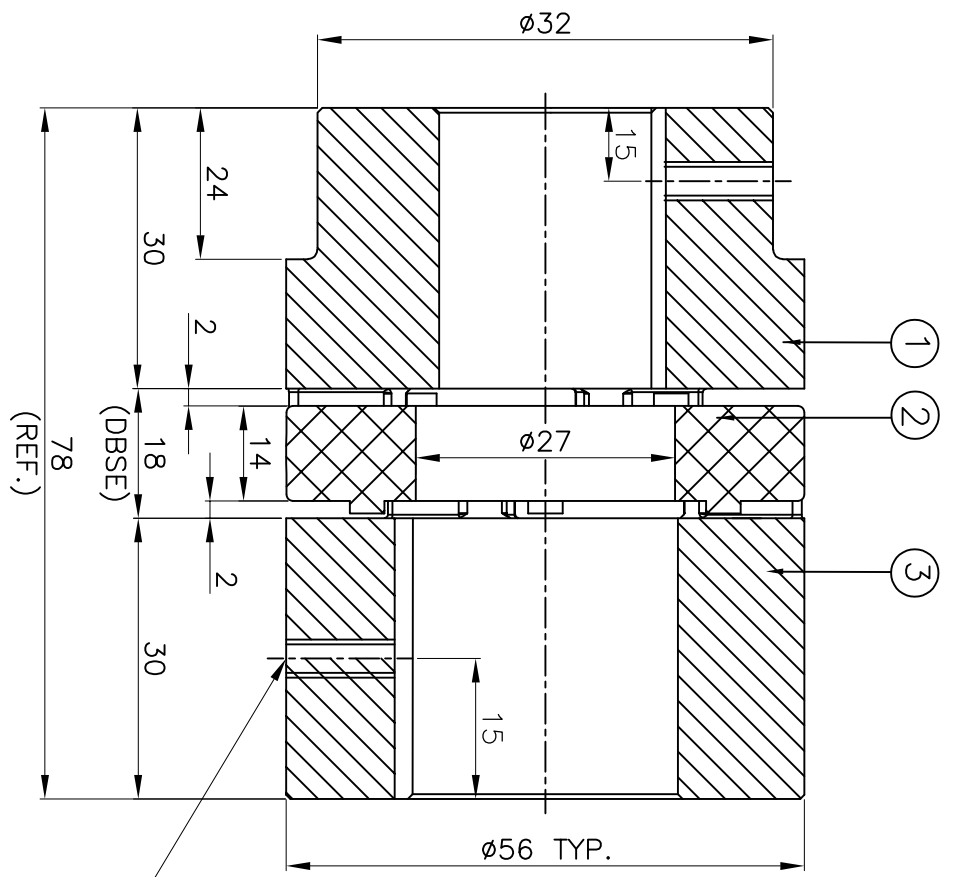

DRIVEN SIDE

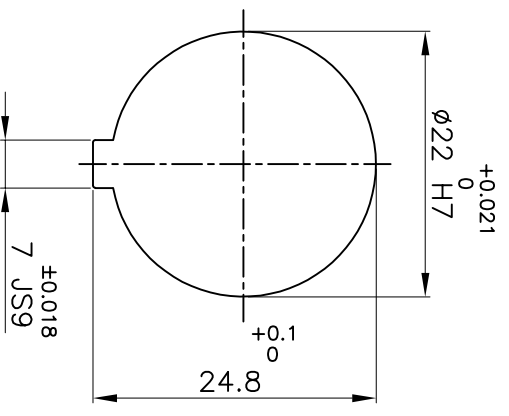

M5X0.8P TAPPED HOLE FOR SET SCREW ON KEYWAY.

APPLICATION DETAILS

APPLICATION	-
RATED POWER	- KW
RATED SPEED	- RPM
RATED TORQUE	- kNm
A.S.F	-

COUPLING SPECIFICATIONS

COUPLING RATING	0.80kW @ 100 RPM
MAX BORE TYPE-III	24mm & 28mm
WEIGHT (APPROX)	0.34 Kg
INERTIA WK ² (APPROX)	19X10 ⁻⁵ kg-m ²
CPLG COMPONENTS DYNAMICALLY BALANCED TO GR.6.3 AS PER ISO 21940-II.	
MAXIMUM MISALIGNMENTS	
AXIAL DEFLECTION	±1.6 mm
ANGULAR DEFLECTION	0.80°
RADIAL DEFLECTION	0.15 mm

S/R NO	DESCRIPTION	MATERIAL	QTY.
3	HUB-II	LM24	1
2	SPIDER	POLYURETHANE (LIGHT IVORY)	1
1	HUB-I	LM24	1

TITLE: **RRJ-24 I/II / - - - -**
 CUSTOMER NAME: **CPLG.**
 MATERIAL: **REFER TABLE**

REV. DWGN NO. DESCRIPTION REV. BY APPD. BY DATE
 RATHI TRANSPOWER PVT LTD PUNE 411014
 DRG. No.: **3 EN-F-112**