

IF IN DOUBT, PLEASE ASK

DO NOT SCALE ALL DIMENSIONS ARE IN mm

J I H G F E D C B A

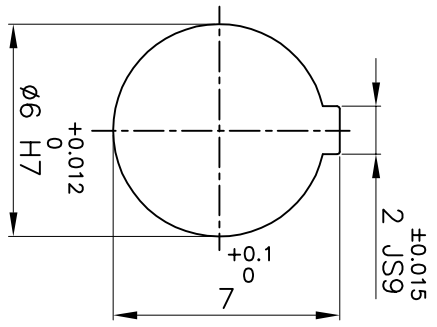

DRIVE SIDE

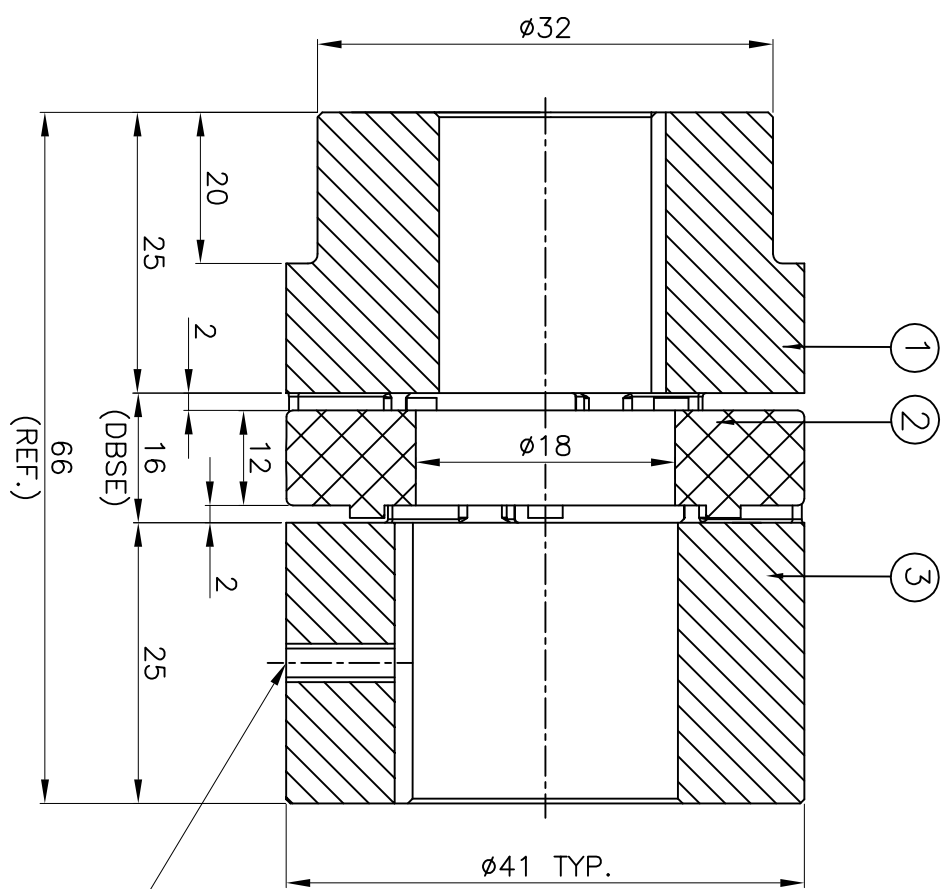

DRIVEN SIDE

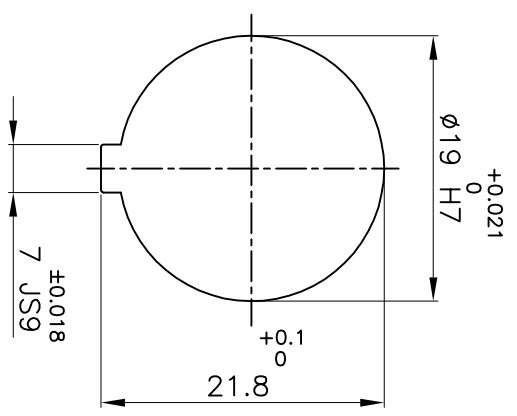

M5X0.8P TAPPED HOLE
FOR SET SCREW ON KEYWAY.

APPLICATION DETAILS

APPLICATION	-
RATED POWER	- KW
RATED SPEED	- RPM.
RATED TORQUE	- Nm
A.S.F.	-

COUPLING CAPACITY

COUPLING RATING	0.1KW AT 100RPM.
RATED TORQUE	10Nm
MAX. BORE TYPE-I & II	19 & 24mm.
WEIGHT (APPROX)	0.14kg
INERTIA (WK ²)	4.3X10 ⁻⁵ kg-m ²

MAX. MISALIGNMENT

AXIAL	±1.6mm
ANGULAR	0.80°
PARALLEL	0.15mm

Sr NO	DESCRIPTION	MATERIAL	QTY.
3	HUB-II	ALUMINIUM	1
2	SPIDER	POLYURETHANE (GRAY)	1
1	HUB-I	ALUMINIUM	1

TITLE: **RRJ-19 I/II /-----**
 CPLG.
 MATERIAL: **REFER TABLE**
 CUSTOMER NAME: **---**

REV. / DMR. NO. / DESCRIPTION / REV. BY / APPD. BY / DATE

Lovejoy
 RATHI TRANSPOWER PVT LTD
 PUNE 411006

DRG No.: ----- / -
 3 EN-F-112

This drawing / information / design is the property of Rathi Transpower Pvt. Ltd. It is confidential & must not be made public or copied without prior written authorization & is subjected to recall at any time. Acceptance of this drawing constitutes full agreement with these conditions