

IF IN DOUBT, PLEASE ASK

J I H G F E D C B A

DO NOT SCALE ALL DIMENSIONS ARE IN mm

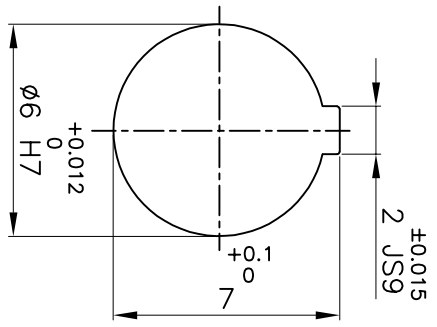

DRIVE SIDE

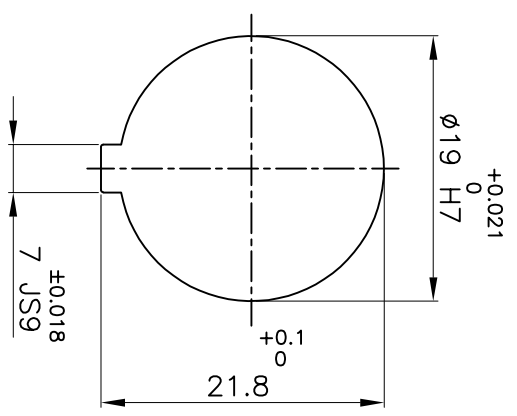
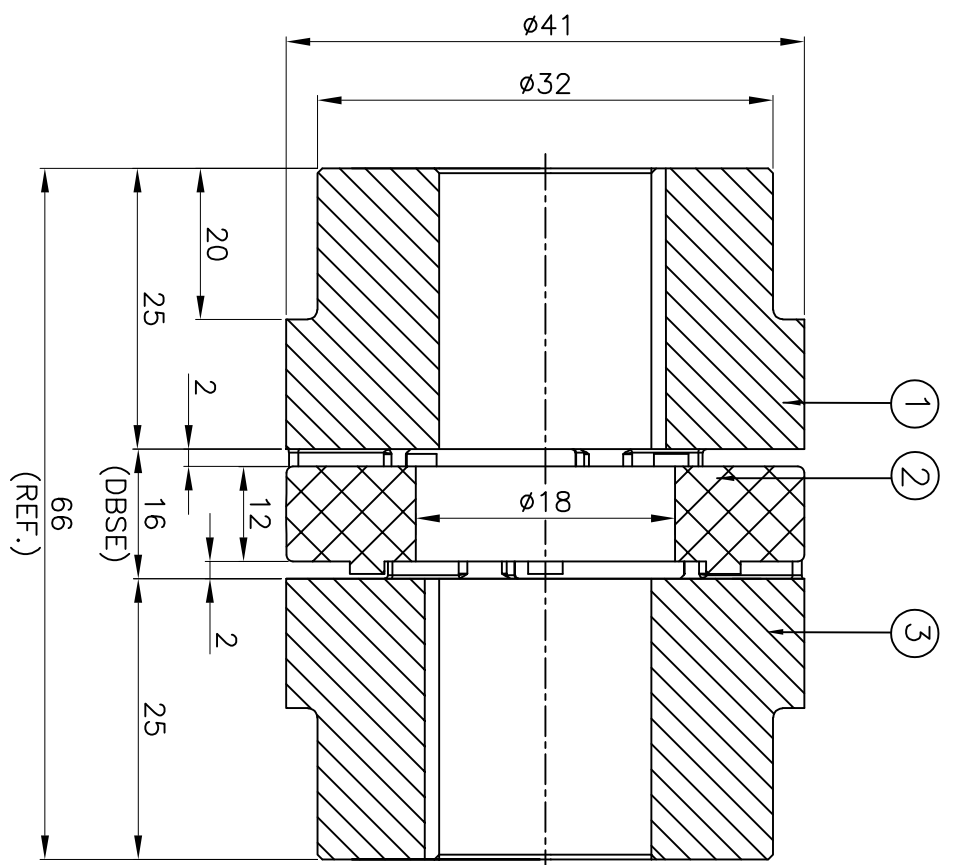

DRIVEN SIDE

APPLICATION DETAILS

APPLICATION	-
RATED POWER	- KW
RATED SPEED	- RPM
RATED TORQUE	- kNm
A.S.F	-

COUPLING SPECIFICATIONS

COUPLING RATING	0.18 KW @ 100 RPM
RATED TORQUE	18 Nm
MAX BORE	19 mm
WEIGHT (APPROX)	0.11 kg
INERTIA Wk^2 (APPROX)	2.3×10^{-5} kg-m ²

CPLG COMPONENTS DYNAMICALLY BALANCED TO GR.6.3 AS PER ISO 21940-II.
MAXIMUM MISALIGNMENTS

AXIAL DEFLECTION	± 1.6 mm
ANGULAR DEFLECTION	0.80°
RADIAL DEFLECTION	0.15 mm

S/R NO	DESCRIPTION	MATERIAL	QTY.
3	HUB-I	LM24	1
2	SPIDER	POLYURETHANE (BLUE)	1
1	HUB-I	LM24	1

TITLE: **RRJ-19 I/1 /- - - -**
CPLG.
 CUSTOMER NAME: -

MATERIAL: **REFER TABLE**

AUTHORITY INITIALS	SIGN	DATE
DRAWN	-	-
CHECKED	-	-
APPROVED	-	-

REV.	DMRN NO.	DESCRIPTION	REV. BY	APPD. BY	DATE

Lovejoy RATHI TRANSPOWER PVT LTD PUNE 411006
 Dwg No.: - - - - - / -
 3 EN-F-112

This drawing / information / design is the property of Rathi Transpower Pvt. Ltd. It is confidential & must not be made public or copied without prior written authorization & is subjected to recall at any time. Acceptance of this drawing constitutes full agreement with these conditions