

DRIVE END

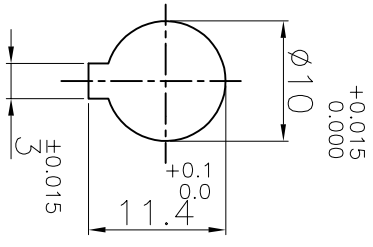

DRIVEN END

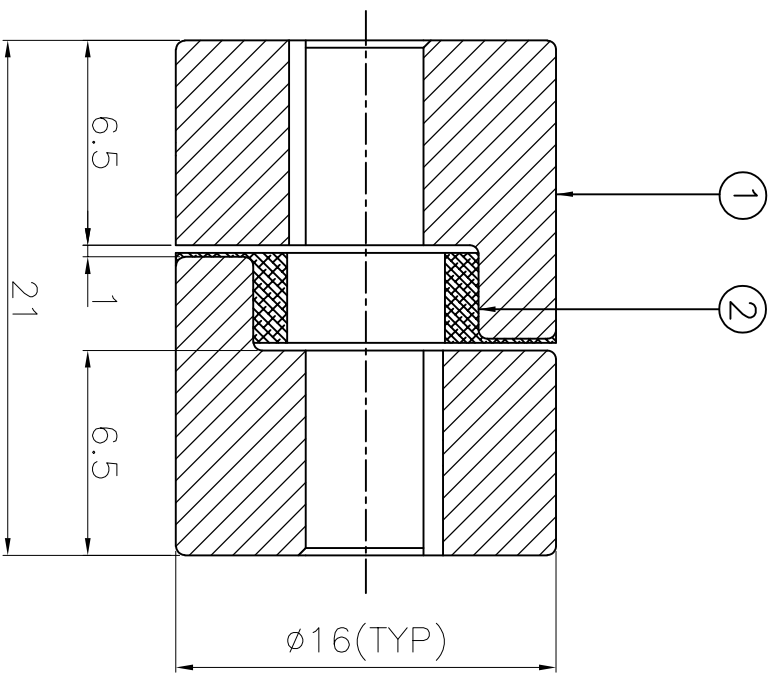
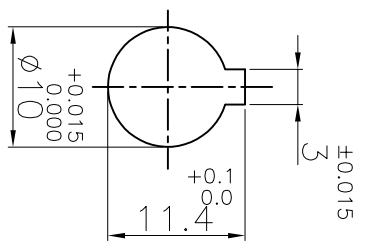

APPLICATION DETAILS

APPLICATION	-
RATED POWER	- KW
RATED SPEED	- RPM
RATED TORQUE	- Nm
A.S.F.	-

COUPLING SPECIFICATIONS

COUPLING RATING	0.004 KW AT 100 RPM
RATED TORQUE	0.38 Nm
MAX. BORE	10 mm
WEIGHT (Approx.)	0.02 Kg
INERTIA (WK ²)	7.28x10 ⁻⁸ Kgm ²
CPLG HUBS DYNAMICALLY BALANCED TO GR.6.3 AS PER ISO 21940-11.	

MAX. MISALIGNMENTS

AXIAL DEFLECTION	±0.5 mm
ANGULAR DEFLECTION	1°
RADIAL DEFLECTION	0.4 mm

SER NO	DESCRIPTION	MATERIAL	QTY.
1	HUB	SINTERED IRON	2
2	SPIDER	NITRILE RUBBER	1

TITLE: **L-35/-** CP1G REFER TABLE

CUSTOMER NAME: -

AUTHORITY	INITIALS	SIGN	DATE
DRAWN	-	-	-
CHECKED	-	-	-
APPROVED	-	-	-

RATHI TRANSPOWER PVT LTD
PUNE 411014

DRG. No.: -
SCALE: REF. No.: -