

J	I	H	G	F	E	D	C	B	A
SAP CODE									

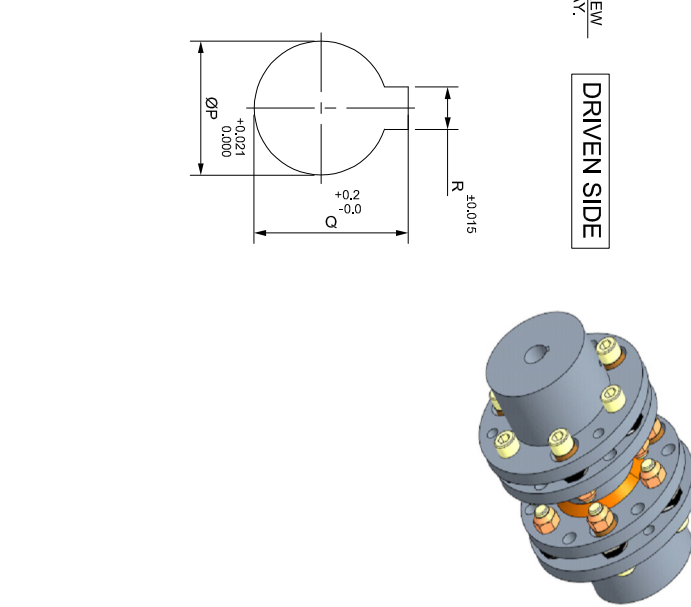
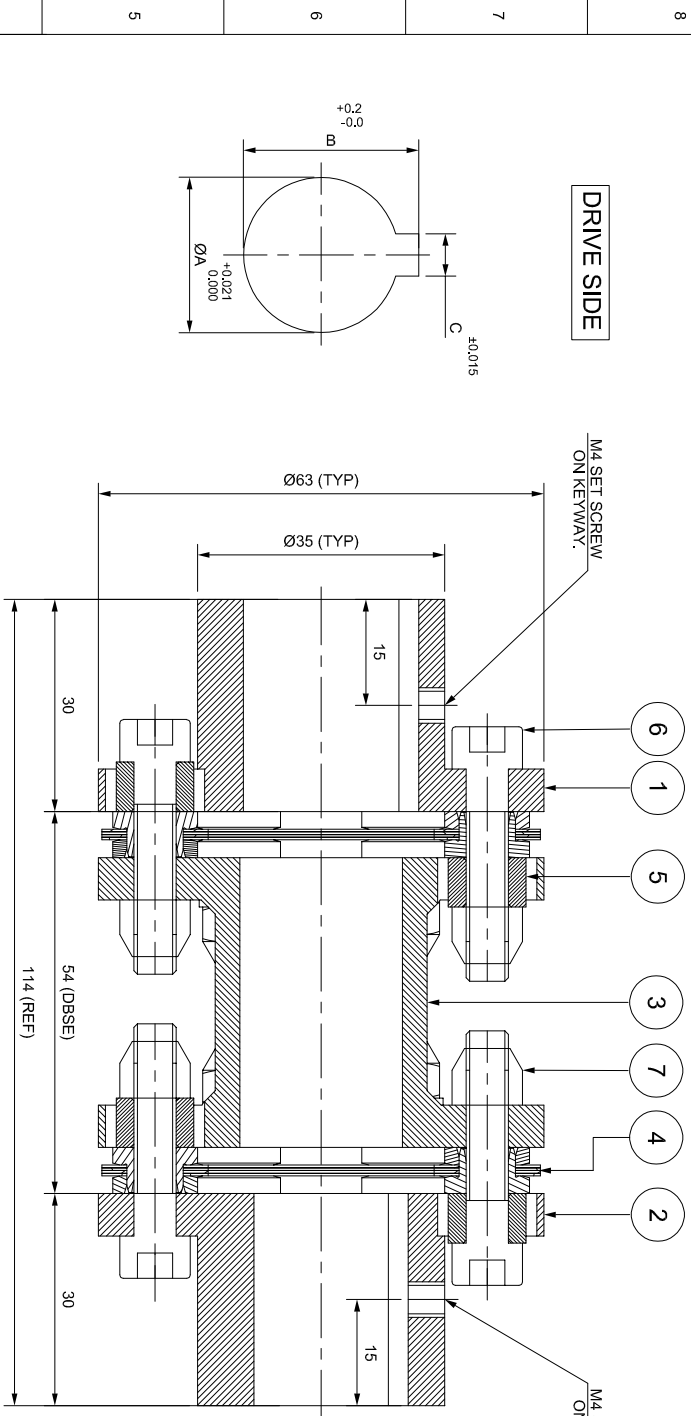

4	APPLICATION DETAILS	-
	RATED POWER	-
	RATED SPEED	-
	RATED TORQUE	-
	A.S.F.	-
3	COUPLING SPECIFICATIONS	-
	COUPLING RATING	1 kW @ 100 RPM
	CONTINUOUS TORQUE	95 Nm
	PEAK TORQUE	190 Nm
	SHORT CIRCUIT TORQUE	333 Nm
	MAX. BORE	22 mm
2	MAX. SPEED	7500 RPM
	WEIGHT (Approx.)	1.914 kg
	INERTIA (Wk ²)	0.001 kg.m ²
	GD ^{v2}	0.004 kg.m ²
	TORSIONAL STIFFNESS	0.011 MNm/rad
1	CPLG DYNAMIC BALANCING	GR. 2.5, ISO 21940-11
	MAX. MISALIGNMENT	± 1 mm
	AXIAL	± 1 mm
	ANGULAR	0.75° PER STACK
	RADIAL	0.70 mm

REV.	DMRN NO.	DESCRIPTION	REV. BY	APPD. BY	DATE

7	CLEVELOCK NUT	GR. 10	12
6	COUPLING BOLT	AH BOLT GR. 12.9 (ASTM 574M)	12
5	SLEEVE	ASTM A 1040	12
4	ELEMENT BLADE ASSEMBLY	AISI SS 301	2
3	SPACER	ASTM A 1068 ASTM A-36 / ASTM A 1040	1
2	DRIVEN HUB (I)	ASTM A 1040	1
1	DRIVE HUB (I)	ASTM A 1040	1

TITLE:	RLM-10(64)M /XXXX CPLG	REFER TABLE
CUSTOMER NAME:	RATHI TRANSPOWER PVT. LTD.	
	PUNE, INDIA	
	ANG. OF PROJ.	DRG. NO.:
		L/RLM-XXXXX0
	AUTHORITY	INITIALS
	DRAWN	SIGN
	CHECKED	DATE
	APPROVED	
	SCALE: NTS	REF. NO.

This drawing/ information/ design is the property of Rathi Transpower Pvt. Ltd. It is confidential & must not be made public or copied without prior written authorization & is subjected to recall at any time. Acceptance of this drawing constitutes full arrangements with these conditions.