

J I H G F E D C B A

DRIVE END

DRIVEN END

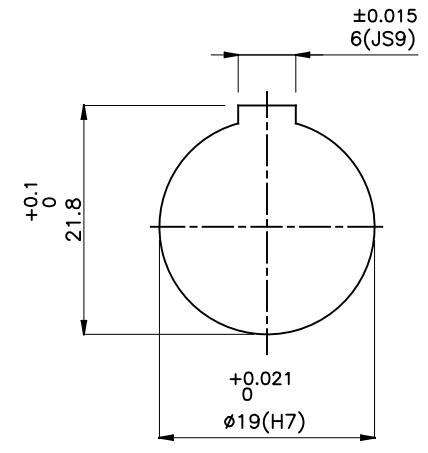
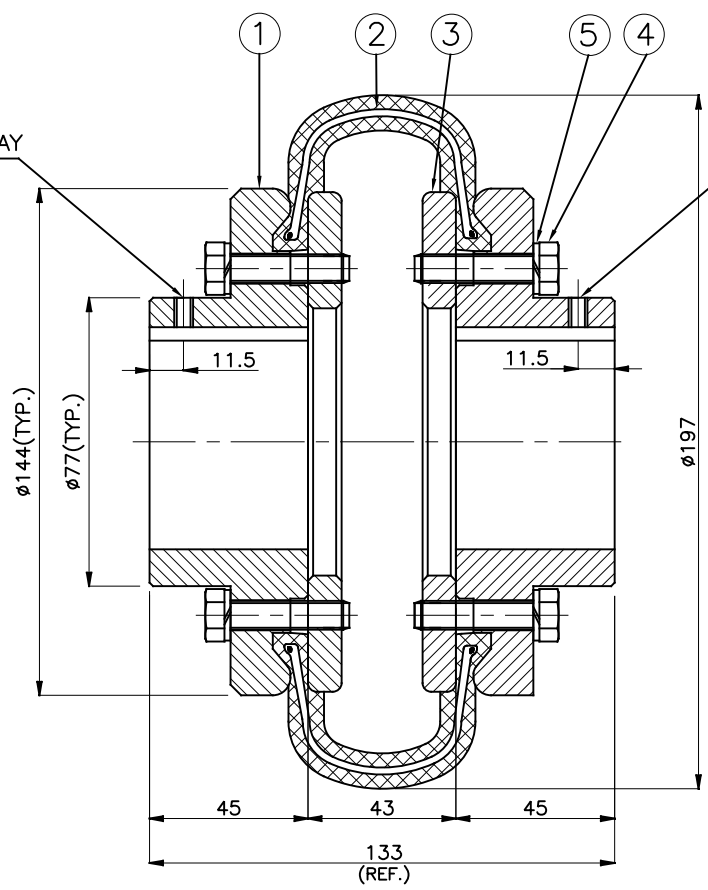
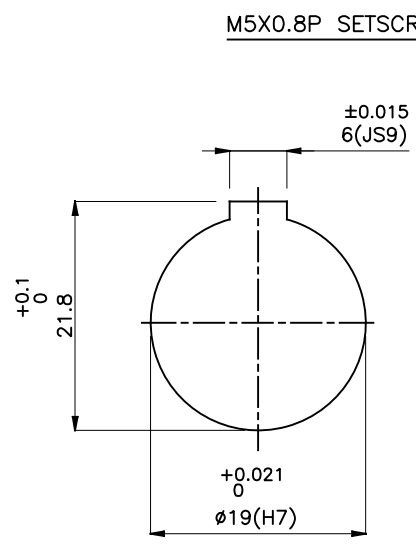

APPLICATION DETAILS

APPLICATION	-
RATED POWER	-
RATED SPEED	-
RATED TORQUE	-
A.S.F.	-

COUPLING SPECIFICATIONS

COUPLING RATING	2.62 kW @ 100 RPM
RATED TORQUE	0.250 kNm.
PEAK TORQUE	0.500 kNm.
MAX. SPEED	3600 rpm.
MAX. BORE	50 mm
WEIGHT(Approx.)	8.0 Kg
INERTIA (WK ²)	0.020 Kgm ²

COUPLING HUBS DYNAMICALLY BALANCED TO GR.6.3 AS PER ISO: 1940-1.

MAX. MISALIGNMENTS

AXIAL DEFLECTION	±2.3 mm.
ANGULAR DEFLECTION	2'
RADIAL DEFLECTION	1.9 mm

SR NO	DESCRIPTION	MATERIAL	QTY.
5	SPRING WASHER	SPRING STEEL	10
4	HEX HEAD BOLT	HIGH TENSILE STEEL	10
3	CLAMPING RING	M.S. IS 2062	2
2	TYRE	NATURAL RUBBER	1
1	HUB	CI IS-210 GR.FG 260	2

REV.	DMRN NO.	DESCRIPTION	REV. BY	APPD. BY	DATE

TITLE: **T-7 B /---- CPLG.** MATERIAL: REFER TABLE

CUSTOMER NAME: _____

SCALE: NTS REF. No.: _____

RATHI RATHI TRANSPower PVT LTD PUNE 411014 DRG. No.: _____

This drawing / information / design is the property of Rathi Transpower Pvt. Ltd. It is confidential & must not be made public or copied without prior written authorization & is subjected to recall at any time. Acceptance of this drawing constitutes full agreement with these conditions