

IF IN DOUBT, PLEASE ASK

DO NOT SCALE ALL DIMENSIONS ARE IN mm

J I H G F E D C B A

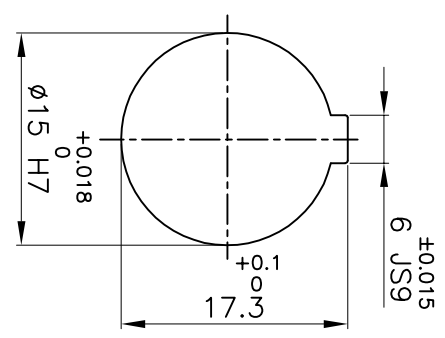
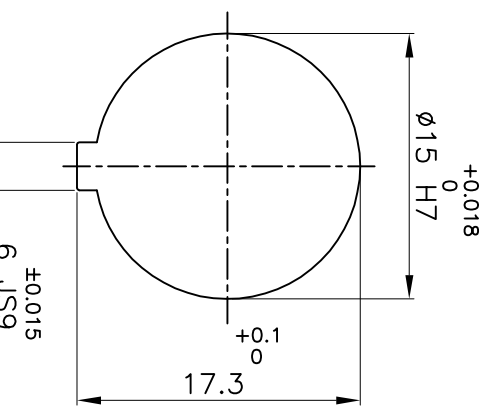
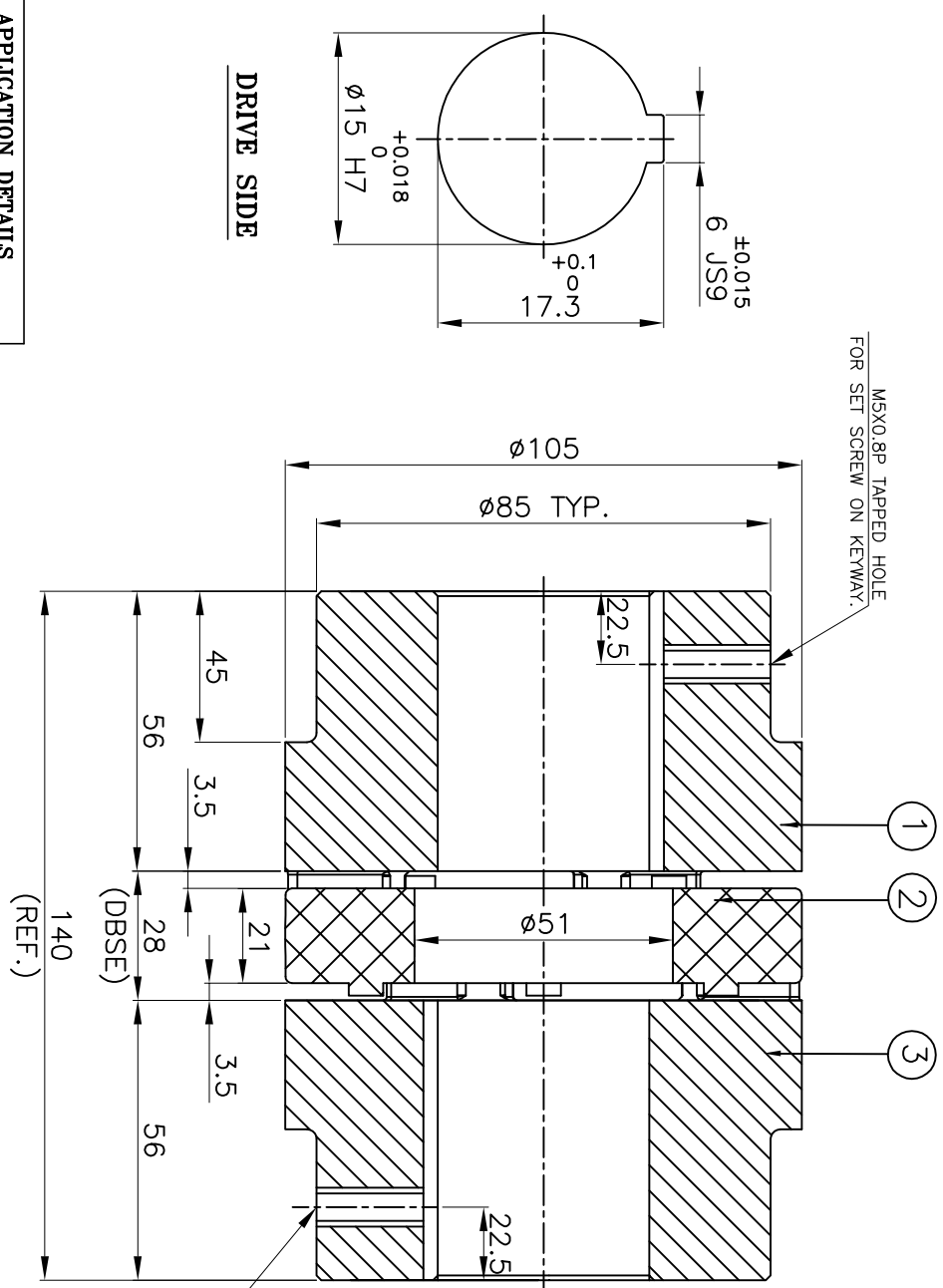

MSX0.8P TAPPED HOLE
FOR SET SCREW ON KEYWAY.

APPLICATION DETAILS

APPLICATION	-
RATED POWER	- KW
RATED SPEED	- RPM.
RATED TORQUE	- Nm
A.S.F.	-

COUPLING CAPACITY

COUPLING RATING	6.94KW AT 100RPM.
RATED TORQUE	667Nm
MAX. BORE TYPE-I	52mm
WEIGHT (APPROX)	4.4kg
INERTIA (WK ²)	6.2X10 ⁻³ kg-m ²

MAX. MISALIGNMENT

AXIAL	±3.0mm
ANGULAR	1°
PARALLEL	0.35mm

Sr NO	DESCRIPTION	MATERIAL	QTY.
3	HUB-I	C.I. IS:210 FG 260	1
2	SPIDER	POLYURETHANE (LIGHT MORY)	1
1	HUB-I	C.I. IS:210 FG 260	1

TITLE: **RRJ-48 I/1 /-----**
 CPLG. REFER TABLE
 CUSTOMER NAME: -

RATHI RATHI TRANSPOWER PVT LTD
 PUNE 411006

DRG. No.: -----/-----

3 EN-F-112

This drawing / information / design is the property of Rathi Transpower Pvt. Ltd. It is confidential & must not be made public or copied without prior written authorization & is subjected to recall at any time. Acceptance of this drawing constitutes full agreement with these conditions