

DRIVE SIDE

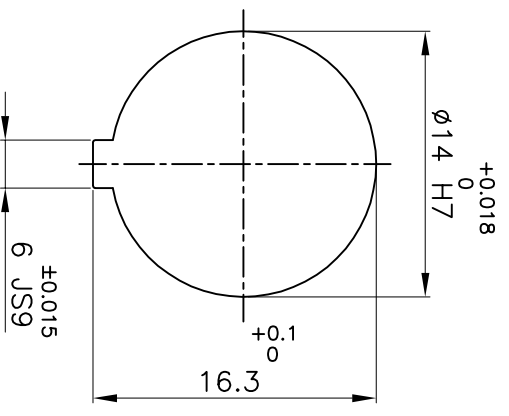
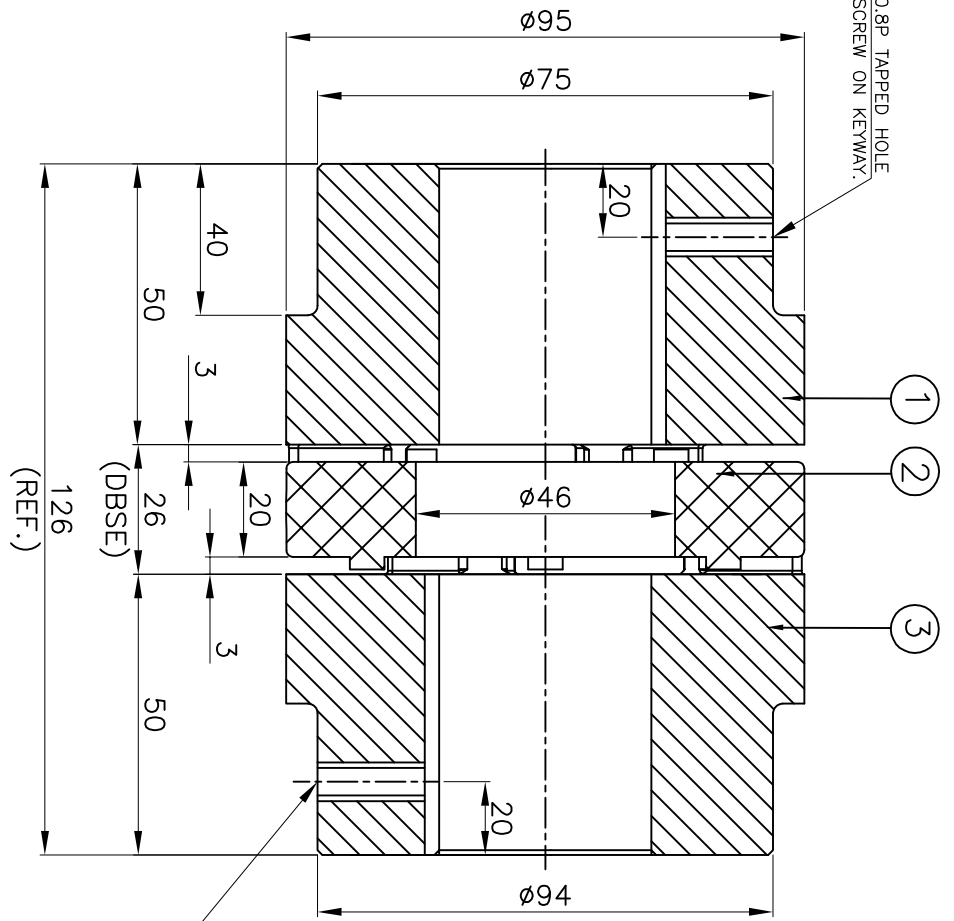

DRIVEN SIDE

(REF.)

MSX0.8P TAPPED HOLE
FOR SET SCREW ON KEYWAY.

APPLICATION DETAILS

APPLICATION	-
RATED POWER	- KW
RATED SPEED	- RPM
RATED TORQUE	- Nm
A.S.F.	-

COUPLING CAPACITY

COUPLING RATING	5.86KW AT 100RPM.
RATED TORQUE	560Nm
MAX. BORE TYPE-I & II	45 & 55mm
WEIGHT (APPROX)	3.8kg
INERTIA (WK ²)	5.9X10 ⁻³ kg-m ²

MAX. MISALIGNMENT

AXIAL	±2.3mm
ANGULAR	0.90°
PARALLEL	0.30mm

S/N	SR NO	DESCRIPTION	MATERIAL	QTY.
3	HUB-II	C.I. IS:210 FG 260		1
2	SPIDER	POLYURETHANE (LIGHT IVORY)		1
1	HUB-I	C.I. IS:210 FG 260		1

TITLE: **RRJ-42 I/II /-----**
CPLG.
 MATERIAL: **REFER TABLE**
 CUSTOMER NAME: **RAHI**
 AUTHORITY INITIALS: **RAHI**
 DRAWN: **RAHI**
 CHECKED: **RAHI**
 APPROVED: **RAHI**
 SCALE: NTS REF. No.: **RAHI**
 DRG. No.: **RAHI**

REV. DWGN NO. DESCRIPTION REV. BY APPD. BY DATE
RATHI
RATHI TRANSPOWER PVT LTD
PUNE 411014
3 EN-F-112