

ERP CODE: _____

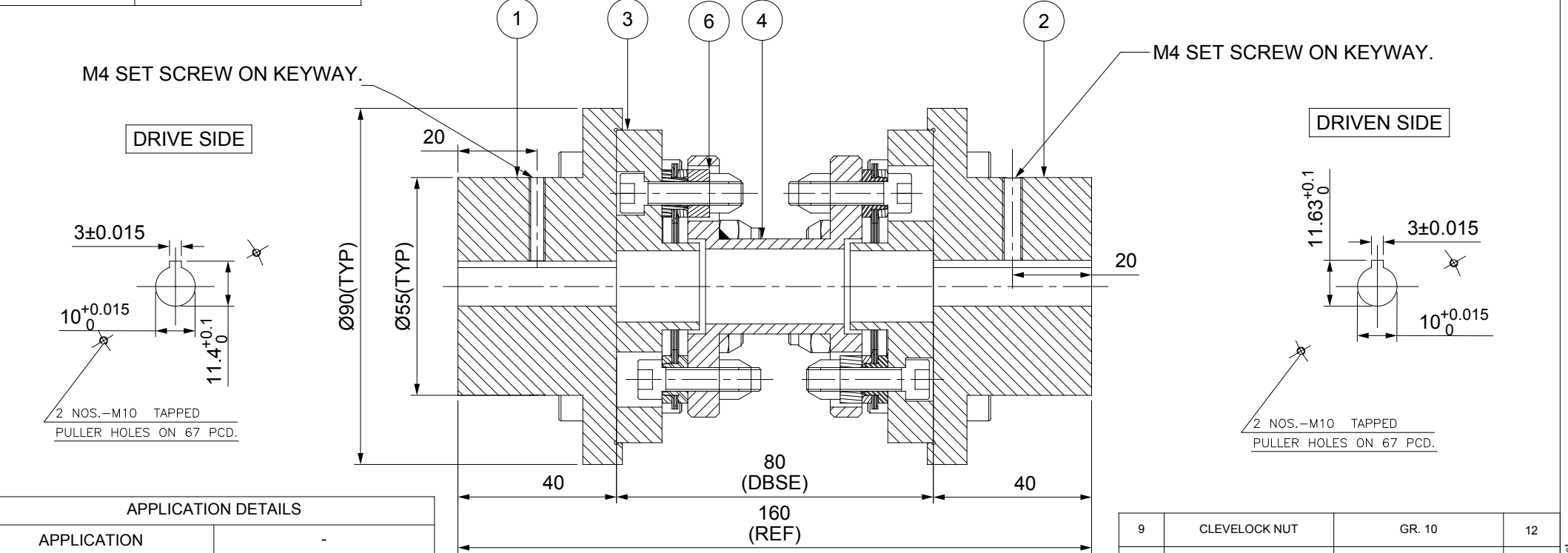

APPLICATION DETAILS	
APPLICATION	-
RATED POWER	-
RATED SPEED	-
RATED TORQUE	-
A.S.F.	-
COUPLING SPECIFICATIONS	
COUPLING RATING	1.0 KW @ 100 RPM
RATED TORQUE	96 Nm
MAX. BORE	38 mm
WEIGHT (Approx.)	3.364 kg
INERTIA (WK ²)	0.002 kg.M ²
TORSIONAL STIFFNESS	0.018 MNm/rad
CPLG DYNAMIC BALANCED TO GR 6.3 AS PER ISO 1940- 1	
MAX. MISALIGNMENT	
AXIAL DEFLECTION	± 1 mm
ANGULAR DEFLECTION	0.75°
RADIAL MISALIGNMENT	0.013 mm

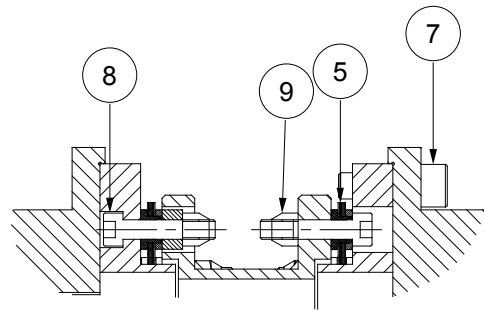

TIGHTENING TORQUE :-
 1) SR.NO.8 COUPLING BOLT = 12.1 Nm
 2) SR.NO.7 ATTACHMENT BOLT = 12.1 Nm

9	CLEVELOCK NUT	GR. 10	12
8	COUPLING BOLT	AH BOLT GR. 12.9	12
7	ATTACHMENT BOLT (III)	AH BOLT GR. 12.9	12
6	S SLEEVE	ASTM A 1040	6
5	ELEMENT BLADE ASSEMBLY	SS 301	2
4	SPACER	ASTM A 1040 / ASTM A 36, ASTM A106B	1
3	ADAPTER III/IV	ASTM A 1040	2
2	DRIVEN HUB (III)	ASTM A 1040	1
1	DRIVE HUB (III)	ASTM A 1040	1
SR.NO.	DESCRIPTION	MATERIAL	QTY.

MATERIAL:	AUTHORITY	INITIALS	SIGN	DATE
REM-8(80) III/III /XXXX CPLG	REFER TABLE	DRAWN	-	-
CUSTOMER NAME:		CHECKED	-	-
		APPROVED	-	-
		SCALE: 1:1	REF. NO.	
		ANG. OF PROJ.	DRG.NO.:	
		RATHI		XXXX
		RATHI TRANSPOWER PVT LTD		
		PUNE-411014		

REV	DMRN NO.	DESCRIPTION	REV. BY	APPD. BY	DATE

This drawing/information/design is the property of Rathi Transpower Pvt. Ltd. It is confidential & must not be made public or copied without prior written authorization & is subjected to arrangements with these conditions.