

J I H G F E D C B A

DRIVE END

DRIVEN END

M6x1P SETSCREW ON KEYWAY

M6x1P SETSCREW ON KEYWAY

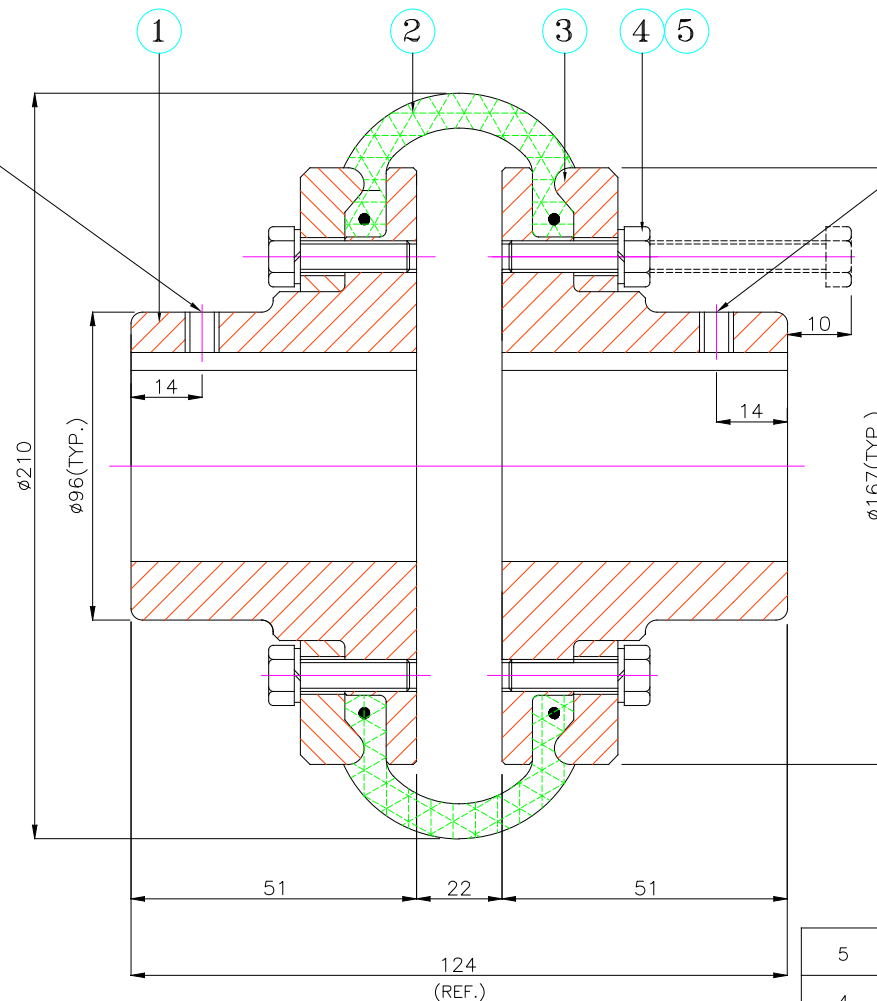
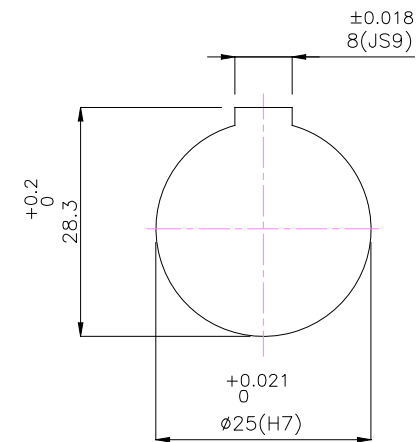
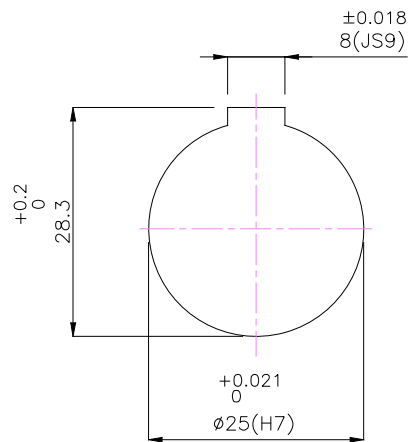

**APPLICATION DETAILS**

APPLICATION	-
RATED POWER	-
RATED SPEED	-
RATED TORQUE	-
A.S.F.	-

**COUPLING SPECIFICATIONS**

COUPLING RATING	3.93 kW @ 100 RPM
RATED TORQUE	0.375 kNm.
PEAK TORQUE	0.750 kNm.
MAX. SPEED	3100 rpm.
MAX. BORE	63 mm
WEIGHT(Approx.)	10.5 Kg
INERTIA (WK <sup>2</sup> )	0.040 Kg <sup>m</sup> <sup>2</sup>

COUPLING HUBS DYNAMICALLY BALANCED TO GR.6.3 AS PER ISO: 1940-1.

**MAX. MISALIGNMENTS**

AXIAL DEFLECTION	±2.6 mm.
ANGULAR DEFLECTION	2°
RADIAL DEFLECTION	2.1 mm

5	SPRING WASHER	SPRING STEEL	12
4	HEX HEAD BOLT	HIGH TENSILE STEEL	12
3	CLAMPING RING	S.G. IRON-400/15	2
2	TYRE	NATURAL RUBBER	1
1	HUB	CI IS-210 GR.FG 260	2
SR NO	DESCRIPTION	MATERIAL	QTY.

REV.	DMRN NO.	DESCRIPTION	REV. BY	APPD. BY	DATE

TITLE: **T0-8 B /----- CPLG.**

MATERIAL: REFER TABLE

CUSTOMER NAME:

AUTHORITY	INITIALS	SIGN	DATE
DRAWN	-	-	-
CHECKED	-	-	-
APPROVED	-	-	-

SCALE: NTS REF. No.: -

DRG. No.: -----

**RATHI** RATHI TRANSPower PVT LTD PUNE 411014

This drawing / information / design is the property of Rathi Transpower Pvt. Ltd. It is confidential & must not be made public or copied without prior written authorization & is subjected to recall at any time. Acceptance of this drawing constitutes full agreement with these conditions