

IF IN DOUBT, PLEASE ASK

DO NOT SCALE ALL DIMENSIONS ARE IN mm

J I H G F E D C B A

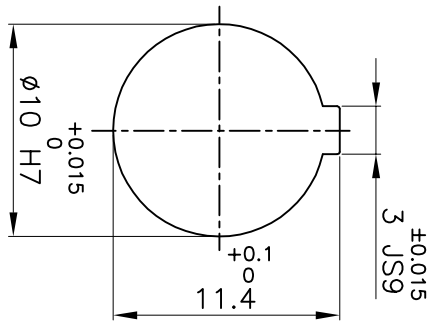

DRIVE SIDE

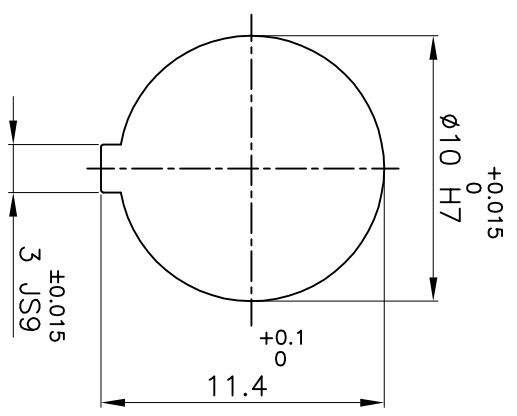
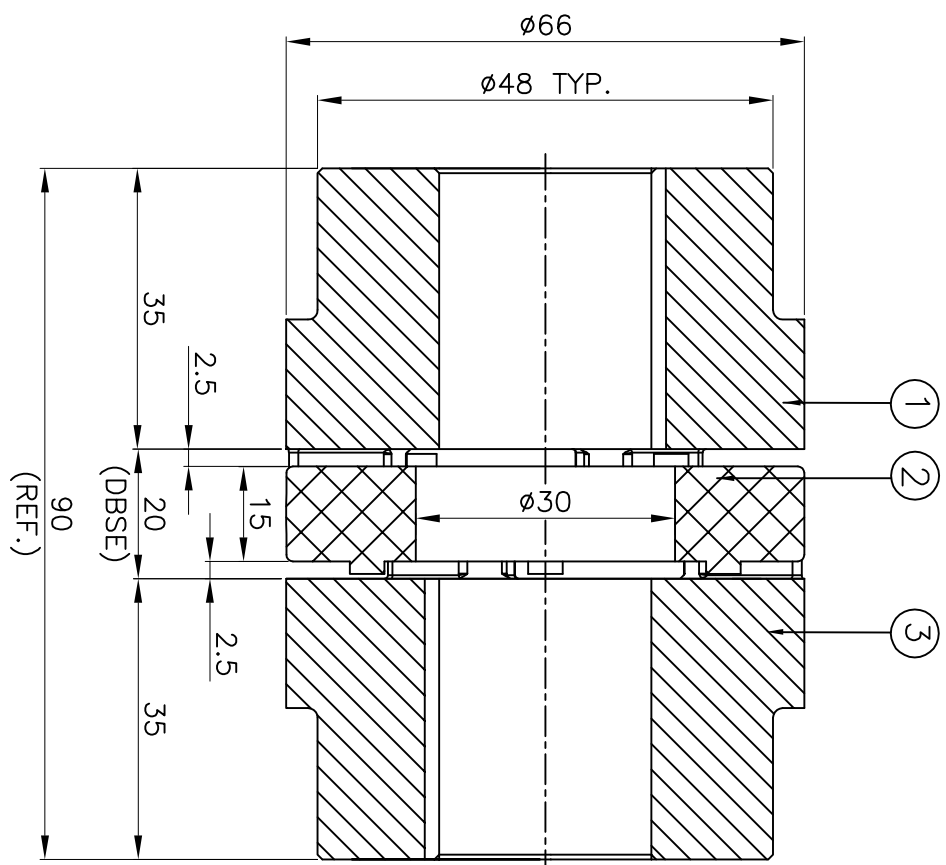

DRIVEN SIDE

APPLICATION DETAILS

APPLICATION	-
RATED POWER	- KW
RATED SPEED	- RPM.
RATED TORQUE	- Nm
A.S.F.	-

COUPLING CAPACITY

COUPLING RATING	0.95KW AT 100RPM.
RATED TORQUE	91Nm
MAX. BORE TYPE-I	10mm
WEIGHT (APPROX)	0.39kg
INERTIA (WK ²)	20X10 ⁻⁵ kg-m ²

MAX. MISALIGNMENT

AXIAL	±2.0mm
ANGULAR	0.80°
PARALLEL	0.20mm

REV.	DNRM NO.	DESCRIPTION	REV. BY	APPD. BY	DATE

S/N	SR NO	DESCRIPTION	MATERIAL	QTY.
3	HUB-I	ALUMINIUM		1
2	SPIDER	POLYURETHANE (GRAY)		1
1	HUB-I	ALUMINIUM		1

TITLE: **RRJ-28 I/1 /-----**
 CPLG.
 MATERIAL: **REFER TABLE**
 CUSTOMER NAME: **---**

Lovejoy
RATHI TRANSPOWER PVT LTD
 PUNE 411014
 Dwg No.: **R/L-----/-**
 3 EN-F-112

This drawing / information / design is the property of Rathi Transpower Pvt. Ltd. It is confidential & must not be made public or copied without prior written authorization & is subjected to recall at any time. Acceptance of this drawing constitutes full agreement with these conditions