

DRIVE SIDE

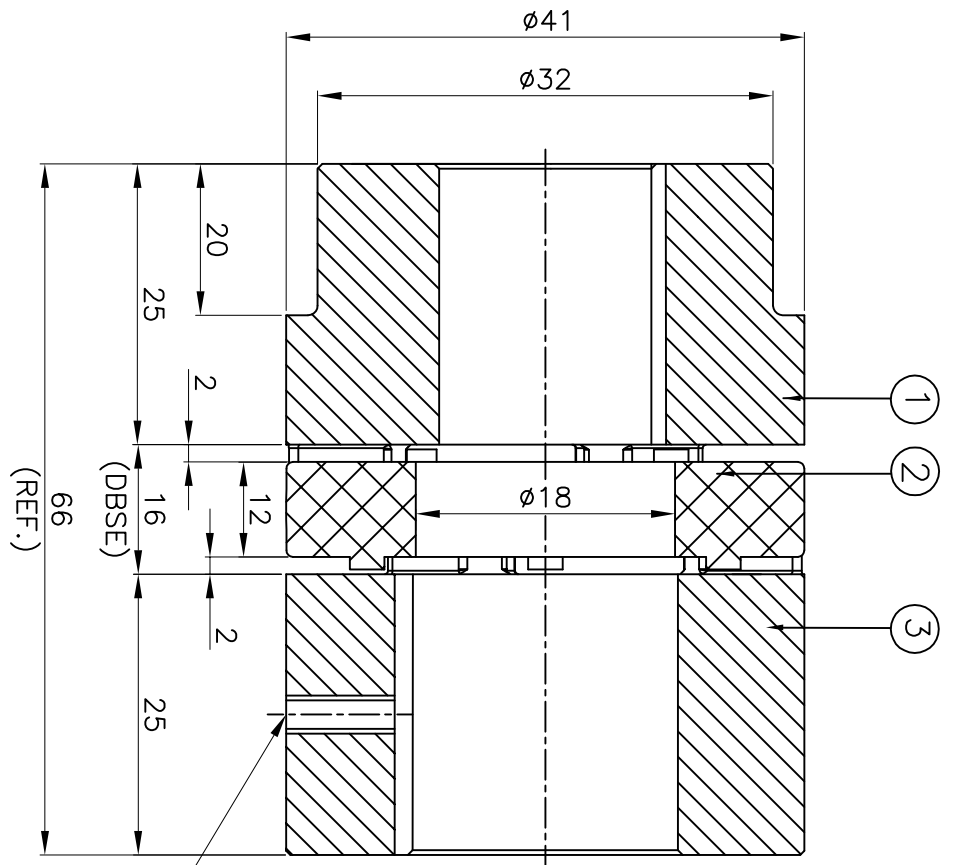

DRIVEN SIDE

M5X0.8P TAPPED HOLE FOR SET SCREW ON KEYWAY.

APPLICATION DETAILS

APPLICATION	-
RATED POWER	- KW
RATED SPEED	- RPM
RATED TORQUE	- Nm
A.S.F.	-

COUPLING CAPACITY

COUPLING RATING	0.22KW AT 100RPM.
RATED TORQUE	21Nm
MAX. BORE TYPE-I & II	19 & 24mm.
WEIGHT (APPROX)	0.11kg
INERTIA (WK ²)	2.3X10 ⁻⁵ kg-m ²

MAX. MISALIGNMENT

AXIAL	±1.6mm
ANGULAR	0.80°
PARALLEL	0.15mm

S/N	SR NO	DESCRIPTION	MATERIAL	QTY.
3	HUB-II	HUB-II	ALUMINIUM	1
2	SPIDER	SPIDER	POLYURETHANE (LIGHT WORY)	1
1	HUB-I	HUB-I	ALUMINIUM	1

TITLE: **RRJ-19 I/II / - - - -**
 CPLG. REFER TABLE
 CUSTOMER NAME: -
 MATERIAL: -
 AUTHORITY INITIALS: -
 DRAWN: -
 CHECKED: -
 APPROVED: -
 SCALE: NTS REF: No.: -
 DATE: -

REV. DWGN NO. DESCRIPTION REV. BY APPD. BY DATE
 RATHI RATHI TRANSPOWER PVT LTD PUNE 411014
 DRG. No.: R/L- - - - - / -
 3 EN-F-112