

**DRIVE SIDE**

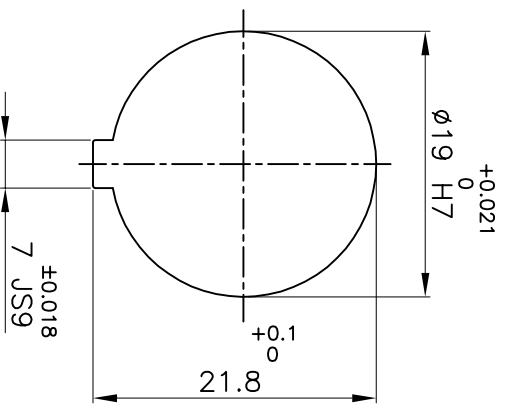
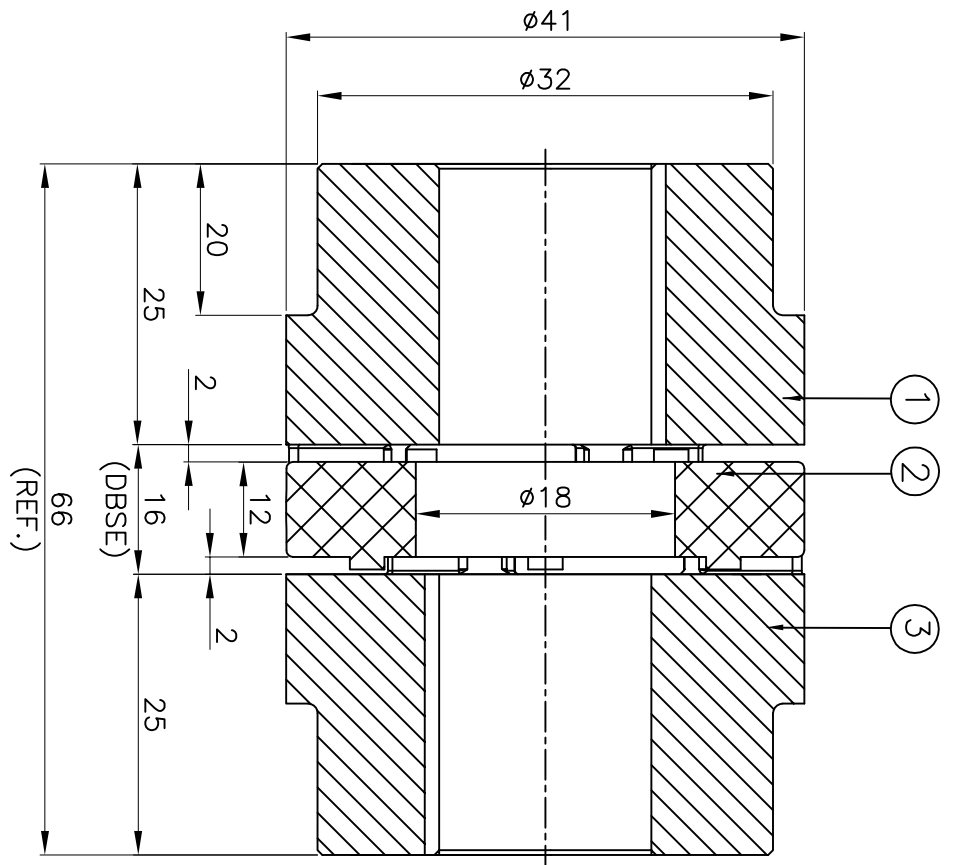

**DRIVEN SIDE**

**APPLICATION DETAILS**

APPLICATION	-
RATED POWER	- KW
RATED SPEED	- RPM
RATED TORQUE	- Nm
A.S.F.	-

**COUPLING CAPACITY**

COUPLING RATING	0.18kW AT 100RPM.
RATED TORQUE	18 Nm
MAX. BORE TYPE-I	19
WEIGHT (APPROX)	0.11kg
INERTIA (WK <sup>2</sup> )	2.3X10 <sup>-5</sup> kg-m <sup>2</sup>

**MAX. MISALIGNMENT**

AXIAL	±1.6mm
ANGULAR	0.80°
PARALLEL	0.15mm

SERIAL NO	DESCRIPTION	MATERIAL	QTY.
3	HUB-I	ALUMINIUM	1
2	SPIDER	POLYURETHANE (BLUE)	1
1	HUB-I	ALUMINIUM	1

TITLE: **RRJ-19 1/1 /-----**  
 CPLG. **REFER TABLE**  
 CUSTOMER NAME: **---**  
 MATERIAL: **---**  
 AUTHORITY INITIALS: **---** SIGN: **---** DATE: **---**  
 DRAWN: **---** CHECKED: **---** APPROVED: **---**  
 SCALE: NTS/REF: No.: **---**

**RATHI** RATHI TRANSPOWER PVT LTD PUNE 411006 DRG. No.: **-----/---**