

DRIVING SIDE

DRIVEN SIDE

STD PULLER HOLES
2 NOS ON EACH HUB

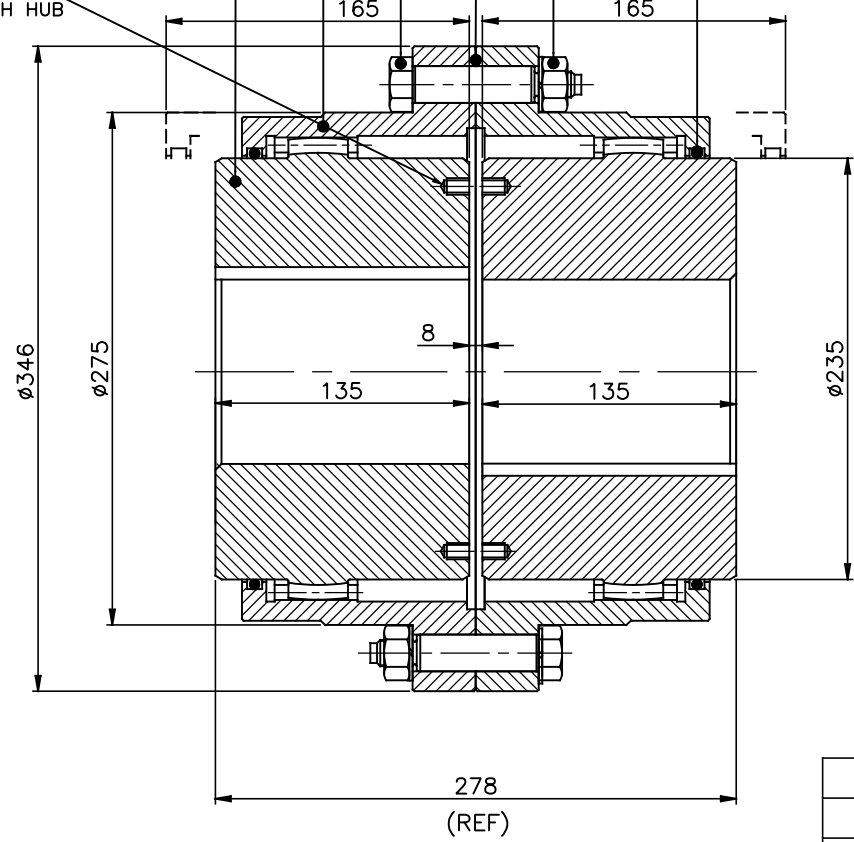
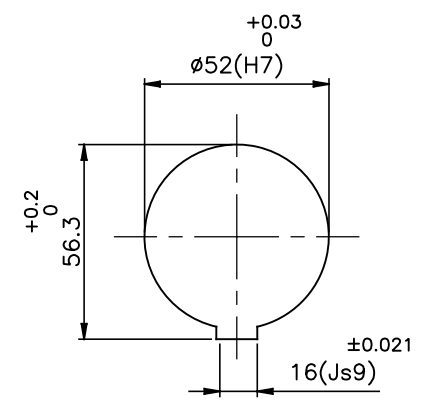
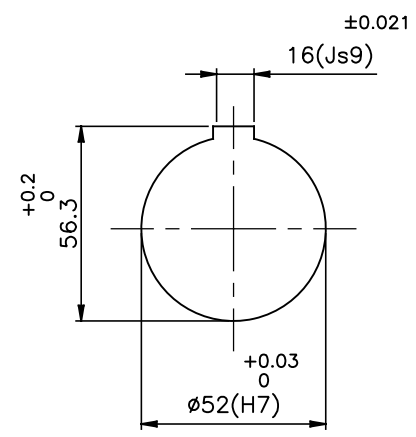

APPLICATION DETAILS

APPLICATION	-
RATED POWER	-
RATED SPEED	-
RATED TORQUE	-
A.S.F.	-

COUPLING SPECIFICATION

COUPLING RATING	472 kW @ 100 RPM
RATED TORQUE	45.073 kNm.
PEAK TORQUE	90.186 kNm
MAX. SPEED	3200 rpm
MAX. BORE	180 mm
INERTIA(WK ²)	1.496 Kgm ²
WEIGHT(Approx.)	132 kg

ONLY CPLG HUBS TO BE DYNAMICALLY BALANCED TO Gr. 6.3, ISO-1940-1

MAX. MISALIGNMENTS

AXIAL DEFLECTION	±1 mm
ANGULAR DEFLECTION	±1.5' Deg./Gear mesh
RADIAL DEFLECTION	2.1 mm

NOTE:-

- * GREASE PLUG ON BOTH SLEEVES WILL BE PROVIDED FOR LUBRICATION.
- * TIGHTENING TORQUE OF THE BOLT(S.NO.-3) - 167 Nm
- * GREASE QTY.- 1.08 Kg (CUSTOMER'S SCOPE)

SR.NO.	DESCRIPTION	MATERIAL	QTY
7	'O' RING	NITRILE RUBBER	2
6	HEX NUT	HIGH TENSILE STEEL	10
5	SPRING WASHER	SPRING STEEL	10
4	GASKET	NON ASBESTOS PAPER	1
3	HEX HEAD BOLT	HIGH TENSILE STEEL	10
2	SLEEVE	C55 BS EN 10277-2	2
1	HUB	C55 BS EN 10277-2	2

REV.	DMRN NO.	DESCRIPTION	REV. BY	APPD. BY	DATE

TITLE: **RGD-45 /- COUPLING**

CUSTOMER NAME: _____

AUTHORITY	INITIALS	SIGN	DATE
DRAWN	-	-	-
CHECKED	-	-	-
APPROVED	-	-	-

SCALE: NTS REF. No.: _____

DRG. No.: _____

RATHI RATHI TRANSPower PVT LTD PUNE 411014

This drawing / information / design is the property of Rathi Transpower Pvt. Ltd. It is confidential & must not be made public or copied without prior written authorization & is subjected to recall at any time. Acceptance of this drawing constitutes full agreement with these conditions