

J I H G F E D C B A

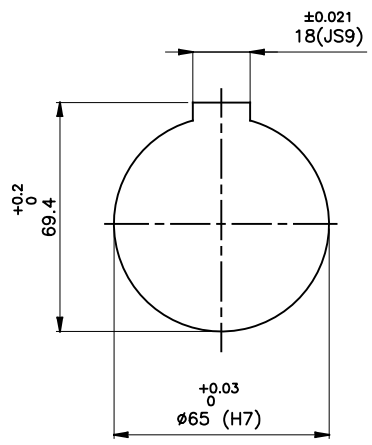

DRIVE END

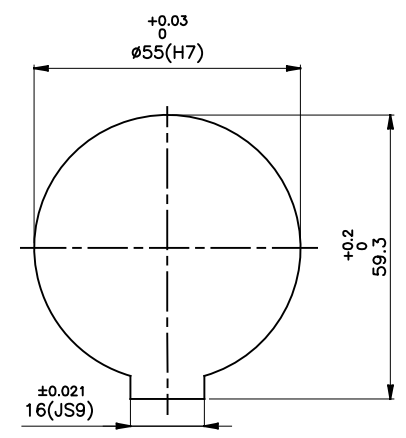
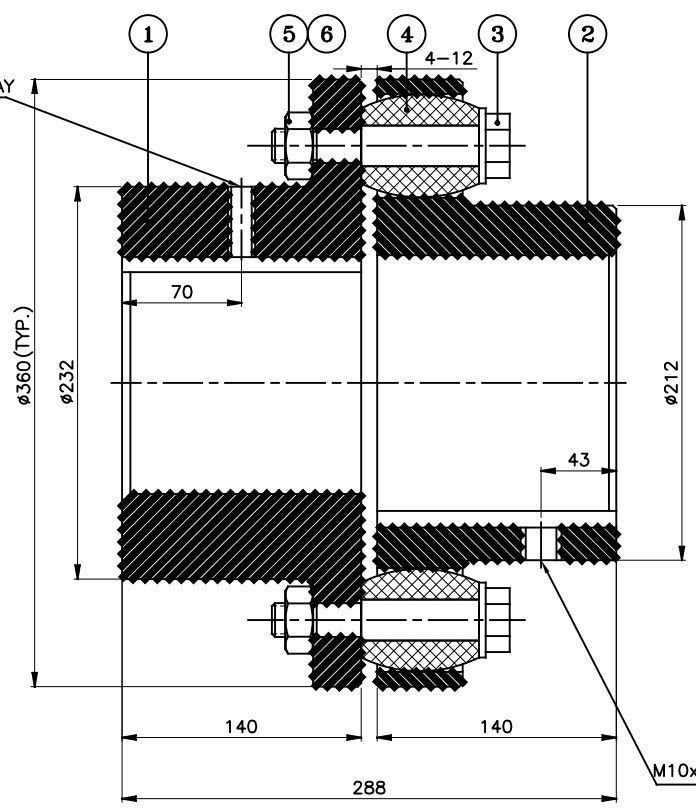

DRIVEN END

M10x1.5P SET SCREW ON KEYWAY

APPLICATION DETAILS		
APPLICATION	-	
RATED POWER	-	
RATED SPEED	-	
RATED TORQUE	-	
A.S.F.	-	
COUPLING SPECIFICATIONS		
COUPLING RATING	233 kW @ 100 RPM	
RATED TORQUE	22.24 kNm.	
PEAK TORQUE	44.49 kNm.	
MAX. SPEED	1900 rpm.	
MAX. BORE	PIN HALF	150 mm
	BUSH HALF	135 mm
WEIGHT (Approx.)	1000 kg	
INERTIA (WK ²)	1.40 kgm²	
COUPLING HUBS DYNAMICALLY BALANCED TO GR. 6.3 AS PER ISO: 1940-1.		
MAX. MISALIGNMENTS		
AXIAL DEFLECTION	±4 mm.	
ANGULAR DEFLECTION	1°	
RADIAL DEFLECTION	0.9 mm	

REV.	DMRN NO.	DESCRIPTION	REV. BY	APPD. BY	DATE

SR NO	DESCRIPTION	MATERIAL	QTY
5	NYLOCK NUT	NYLOCK NUT GR. 8	11
4	BUSH	H TRANS	11
3	PIN	EN-8D/15B25	11
2	BUSH HALF	CI IS-210 Gr.FG-260	1
1	PIN HALF	CI IS-210 Gr.FG-260	1

TITLE:	RB-360-11 /----- CPLG.	MATERIAL:	REFER TABLE	AUTHORITY:	INITIALS	SIGN	DATE
CUSTOMER NAME:				DRAWN	-	-	-
				CHECKED	-	-	-
				APPROVED	-	-	-
				SCALE: NTS	REF. No.:	-	
						-	
				RATHI TRANSPOWER PVT LTD		DRG. No.:	
				PUNE 411014		-	

This drawing / information / design is the property of Rathi Transpower Pvt. Ltd. It is confidential & must not be made public or copied without prior written authorization & is subjected to recall at any time. Acceptance of this drawing constitutes full agreement with these conditions