

J I H G F E D C B A

8

7

6

5

4

3

2

1

24

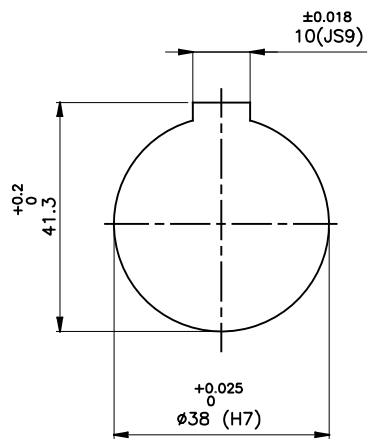

DRIVE END

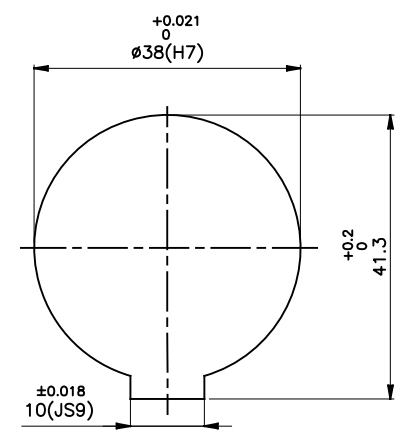
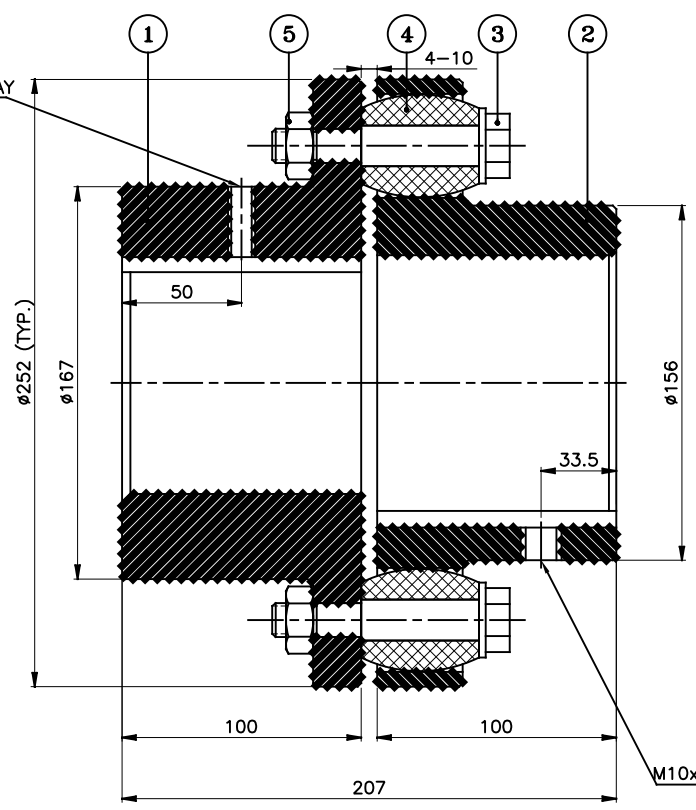

DRIVEN END

APPLICATION DETAILS		
APPLICATION	-	
RATED POWER	-	
RATED SPEED	-	
RATED TORQUE	-	
A.S.F.	-	
COUPLING SPECIFICATIONS		
COUPLING RATING	32 kW @ 100 RPM	
RATED TORQUE	3.0 kNm.	
PEAK TORQUE	6 kNm.	
MAX. SPEED	2700 rpm.	
MAX. BORE	PIN HALF	115 mm
	BUSH HALF	105 mm
WEIGHT(Approx.)	37.17 Kg	
INERTIA (WK ²)	0.26 Kgm ²	
COUPLING HUBS DYNAMICALLY BALANCED TO GR. 6.3 AS PER ISO: 1940-1.		
MAX. MISALIGNMENTS		
AXIAL DEFLECTION	±3 mm.	
ANGULAR DEFLECTION	1°	
RADIAL DEFLECTION	0.6 mm	

SR NO	DESCRIPTION	MATERIAL	QTY
5	NYLOCK NUT	NYLOCK NUT GR. 8	12
4	BUSH	NATURAL RUBBER	12
3	PIN	EN-8D/15B25	12
2	BUSH HALF	CI IS-210 Gr.FG-260	1
1	PIN HALF	CI IS-210 Gr.FG-260	1

REV.	DMRN NO.	DESCRIPTION	REV. BY	APPD. BY	DATE

TITLE: RB-252-12 /----- CPLG.		MATERIAL: REFER TABLE		AUTHORITY	INITIALS	SIGN	DATE
CUSTOMER NAME:				DRAWN	-	-	-
				CHECKED	-	-	-
				APPROVED	-	-	-
				SCALE: NTS	REF. No.:	-	
						-	
				DRG. No.:		-	
				RATHI TRANSPOWER PVT LTD PUNE 411014			

This drawing / information / design is the property of Rathi Transpower Pvt. Ltd. It is confidential & must not be made public or copied without prior written authorization & is subjected to recall at any time. Acceptance of this drawing constitutes full agreement with these conditions