

J I H G F E D C B A

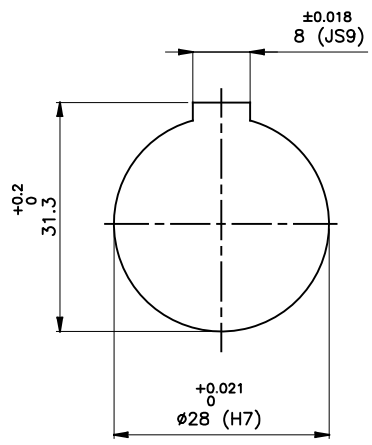

DRIVE END

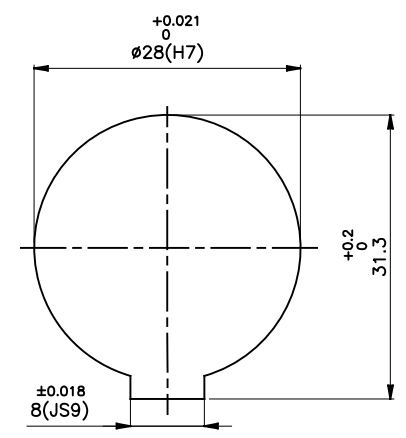
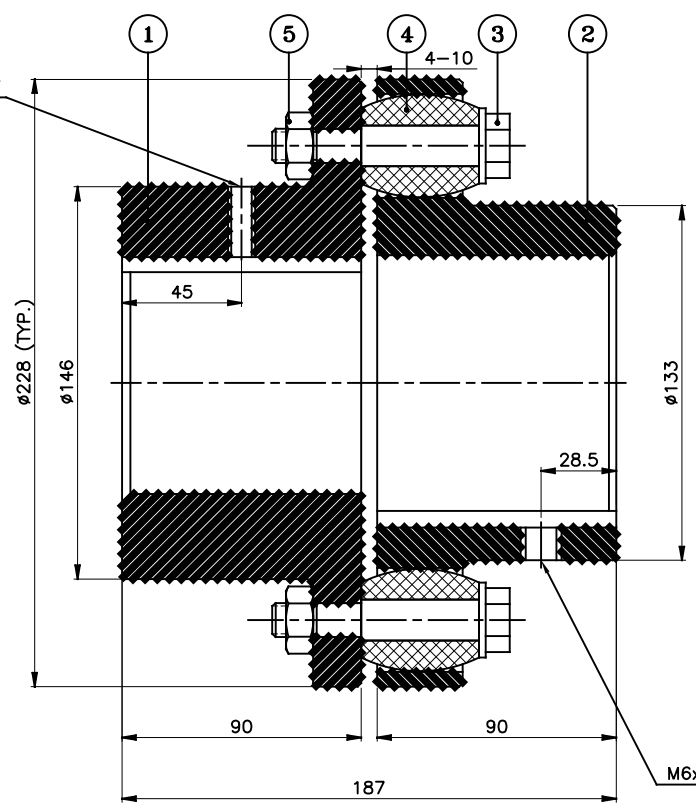

DRIVEN END

APPLICATION DETAILS

APPLICATION	-
RATED POWER	-
RATED SPEED	-
RATED TORQUE	-
A.S.F.	-

COUPLING SPECIFICATIONS

COUPLING RATING	53 kW @ 100 RPM
RATED TORQUE	5.06 kNm.
PEAK TORQUE	10.12 kNm.
MAX. SPEED	3000 rpm.
MAX. BORE	PIN HALF 100 mm BUSH HALF 90 mm
WEIGHT(Approx.)	27.17 Kg
INERTIA (WK ²)	0.15 Kgm ²

COUPLING HUBS DYNAMICALLY BALANCED TO GR. 6.3 AS PER ISO: 1940-1.

MAX. MISALIGNMENTS

AXIAL DEFLECTION	± 3 mm.
ANGULAR DEFLECTION	1'
RADIAL DEFLECTION	0.6 mm

5	NYLOCK NUT	NYLOCK NUT GR. 8	11
4	BUSH	H TRANS	11
3	PIN	EN-8D/15B25	11
2	BUSH HALF	CI IS-210 Gr.FG-260	1
1	PIN HALF	CI IS-210 Gr.FG-260	1
SR NO	DESCRIPTION	MATERIAL	QTY

REV.	DMRN NO.	DESCRIPTION	REV. BY	APPD. BY	DATE

TITLE: **RB-228-11 ---- CPLG.** MATERIAL: REFER TABLE

CUSTOMER NAME: _____

APPROVED: _____

SCALE: NTS REF. No.: _____

RATHI RATHI TRANSPOWER PVT LTD PUNE 411014 DRG. No.: _____

This drawing / information / design is the property of Rathi Transpower Pvt. Ltd. It is confidential & must not be made public or copied without prior written authorization & is subjected to recall at any time. Acceptance of this drawing constitutes full agreement with these conditions