

DRIVE END

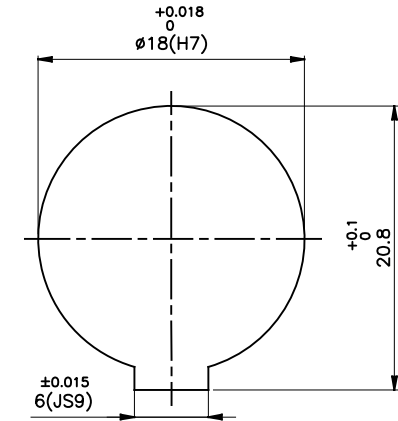
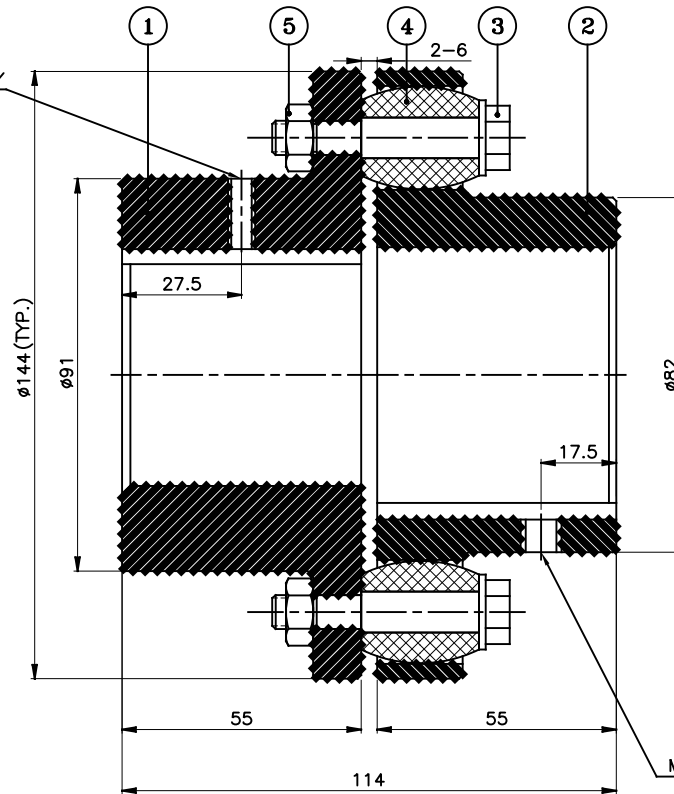

DRIVEN END

APPLICATION DETAILS

APPLICATION	-
RATED POWER	-
RATED SPEED	-
RATED TORQUE	-
A.S.F.	-

COUPLING SPECIFICATIONS

COUPLING RATING	3.3 kW @ 100 RPM
RATED TORQUE	0.315 kNm.
PEAK TORQUE	0.63 kNm.
MAX. SPEED	4900 rpm.
MAX. BORE	PIN HALF 60 mm BUSH HALF 50 mm
WEIGHT(Approx.)	6.15 Kg
INERTIA (WK ²)	0.0172 Kg ^m ²

COUPLING HUBS DYNAMICALLY BALANCED TO GR. 6.3 AS PER ISO: 1940-1.

MAX. MISALIGNMENTS

AXIAL DEFLECTION	± 2 mm.
ANGULAR DEFLECTION	1°
RADIAL DEFLECTION	0.4 mm

5	NYLOCK NUT	NYLOCK NUT GR. 8	6
4	BUSH	NYLOCK NUT	6
3	PIN	EN-8D/15B25	6
2	BUSH HALF	CI IS-210 Gr.FG-260	1
1	PIN HALF	CI IS-210 Gr.FG-260	1
SR NO	DESCRIPTION	MATERIAL	QTY

REV.	DMRN NO.	DESCRIPTION	REV. BY	APPD. BY	DATE

TITLE: **RB-144-6 /----- CPLG.**

MATERIAL: REFER TABLE

CUSTOMER NAME: _____

SCALE: NTS REF. No.: _____

RATHI RATHI TRANSPower PVT LTD PUNE 411014

DRG. No.: _____

This drawing / information / design is the property of Rathi Transpower Pvt. Ltd. It is confidential & must not be made public or copied without prior written authorization & is subjected to recall at any time. Acceptance of this drawing constitutes full agreement with these conditions