

DRIVE END

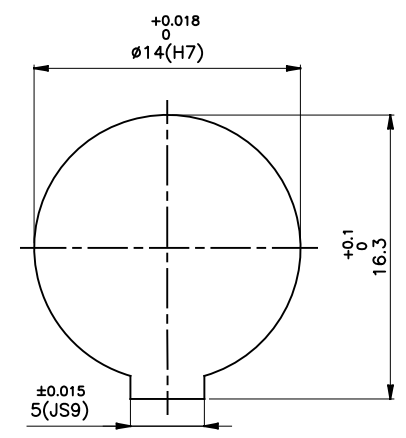
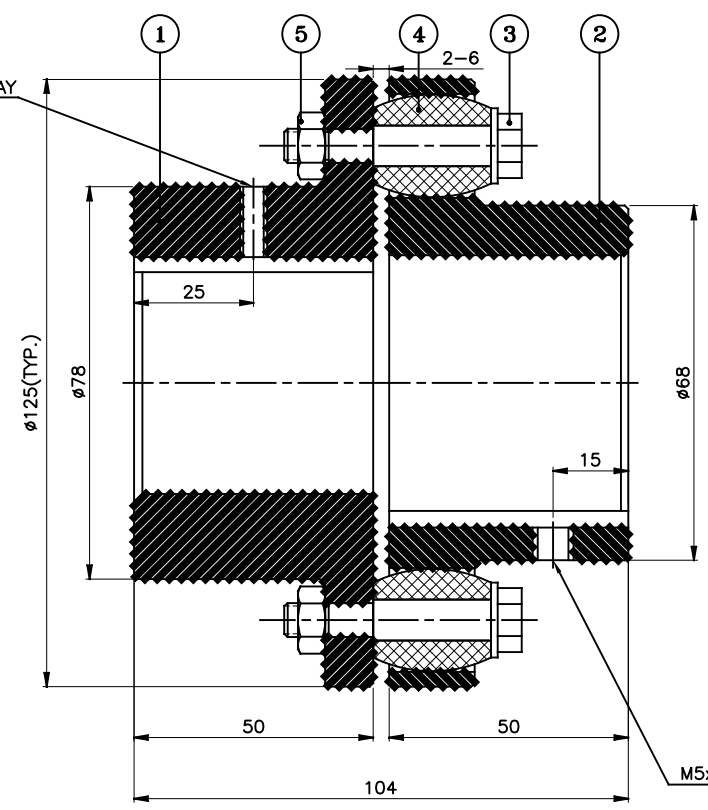

DRIVEN END

APPLICATION DETAILS			
APPLICATION	-		
RATED POWER	-		
RATED SPEED	-		
RATED TORQUE	-		
A.S.F.	-		
COUPLING SPECIFICATIONS			
COUPLING RATING	2.6 kW @ 100 RPM		
RATED TORQUE	0.24 kNm.		
PEAK TORQUE	0.48 kNm.		
MAX. SPEED	5500 rpm.		
MAX. BORE	PIN HALF	50 mm	
	BUSH HALF	45 mm	
WEIGHT(Approx.)	4.3 Kg		
INERTIA (WK ²)	0.0097 Kgm ²		
COUPLING HUBS DYNAMICALLY BALANCED TO GR. 6.3 AS PER ISO: 1940-1.			
MAX. MISALIGNMENTS			
AXIAL DEFLECTION	± 2 mm.		
ANGULAR DEFLECTION	1°		
RADIAL DEFLECTION	0.4 mm		

SR NO	DESCRIPTION	MATERIAL	QTY
5	NYLOCK NUT	NYLOCK NUT GR. 8	4
4	BUSH	POLYURETHANE	4
3	PIN	EN-8D/15B25	4
2	BUSH HALF	CI IS-210 Gr.FG-260	1
1	PIN HALF	CI IS-210 Gr.FG-260	1

REV.	DMRN NO.	DESCRIPTION	REV. BY	APPD. BY	DATE

TITLE:	RB-125-4 /----- CPLG.	MATERIAL:	REFER TABLE	AUTHORITY:	INITIALS	SIGN	DATE
CUSTOMER NAME:				DRAWN	-	-	-
				CHECKED	-	-	-
				APPROVED	-	-	-
				SCALE: NTS	REF. No.:	-	
						-	
				DRG. No.:			-

RATHI RATHI TRANSPower PVT LTD PUNE 411014

This drawing / information / design is the property of Rathi Transpower Pvt. Ltd. It is confidential & must not be made public or copied without prior written authorization & is subjected to recall at any time. Acceptance of this drawing constitutes full agreement with these conditions