

DRIVE END

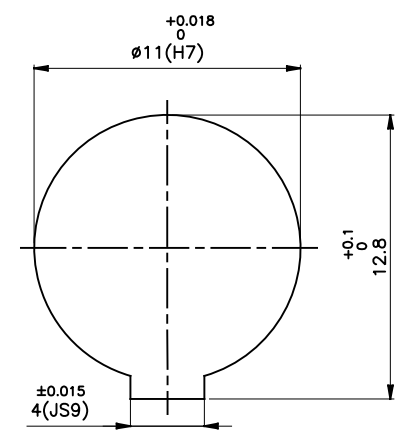
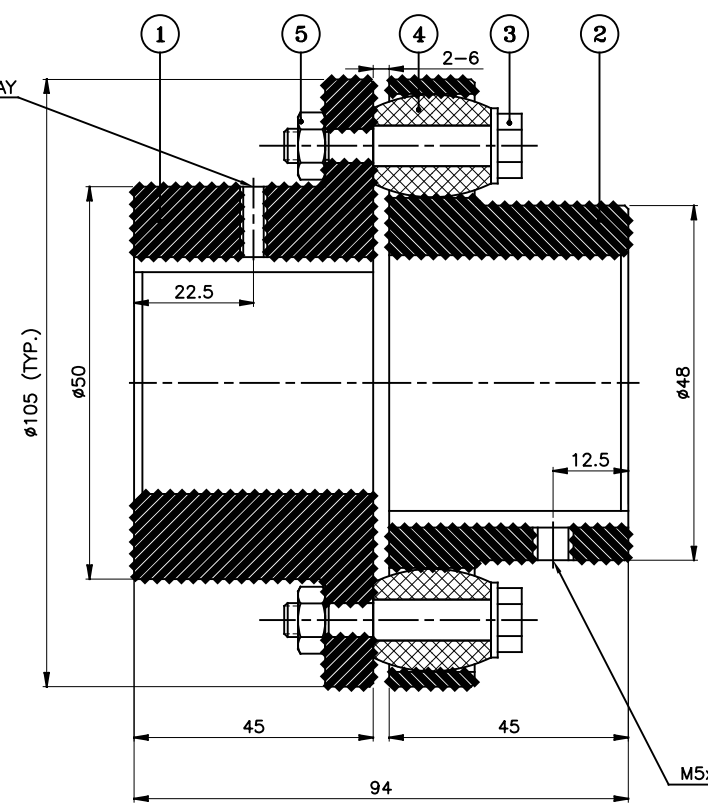

DRIVEN END

APPLICATION DETAILS	
APPLICATION	-
RATED POWER	-
RATED SPEED	-
RATED TORQUE	-
A.S.F.	-

COUPLING SPECIFICATIONS	
COUPLING RATING	2.5 kW @ 100 RPM
RATED TORQUE	0.24 kNm.
PEAK TORQUE	0.48 kNm.
MAX. SPEED	7200 rpm.
MAX. BORE	PIN HALF 32 mm BUSH HALF 30 mm
WEIGHT (Approx.)	2.47 Kg
INERTIA (WK ²)	0.0037 Kg m ²

MAX. MISALIGNMENTS	
AXIAL DEFLECTION	± 2 mm.
ANGULAR DEFLECTION	1°
RADIAL DEFLECTION	0.3 mm

REV.	DMRN NO.	DESCRIPTION	REV. BY	APPD. BY	DATE

SR NO	DESCRIPTION	MATERIAL	QTY
5	NYLOCK NUT	NYLOCK NUT GR. 8	3
4	BUSH	H TRANS	3
3	PIN	EN-8D/15B25	3
2	BUSH HALF	CI IS-210 Gr.FG-260	1
1	PIN HALF	CI IS-210 Gr.FG-260	1

TITLE:	RB-105-3 /----- CPLG.	MATERIAL:	REFER TABLE	AUTHORITY:	INITIALS	SIGN	DATE
CUSTOMER NAME:				DRAWN	-	-	-
				CHECKED	-	-	-
				APPROVED	-	-	-
				SCALE: NTS	REF. No.:	-	
						-	
				DRG. No.:		-----	



RATHI TRANSPower PVT LTD
PUNE 411014

This drawing / information / design is the property of Rathi Transpower Pvt. Ltd. It is confidential & must not be made public or copied without prior written authorization & is subjected to recall at any time. Acceptance of this drawing constitutes full agreement with these conditions