

J I H G F E D C B A

DRIVE END

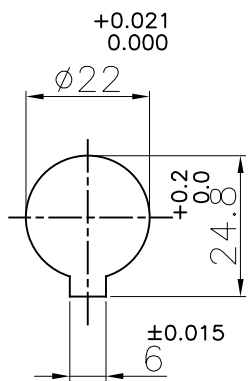

DRIVEN END

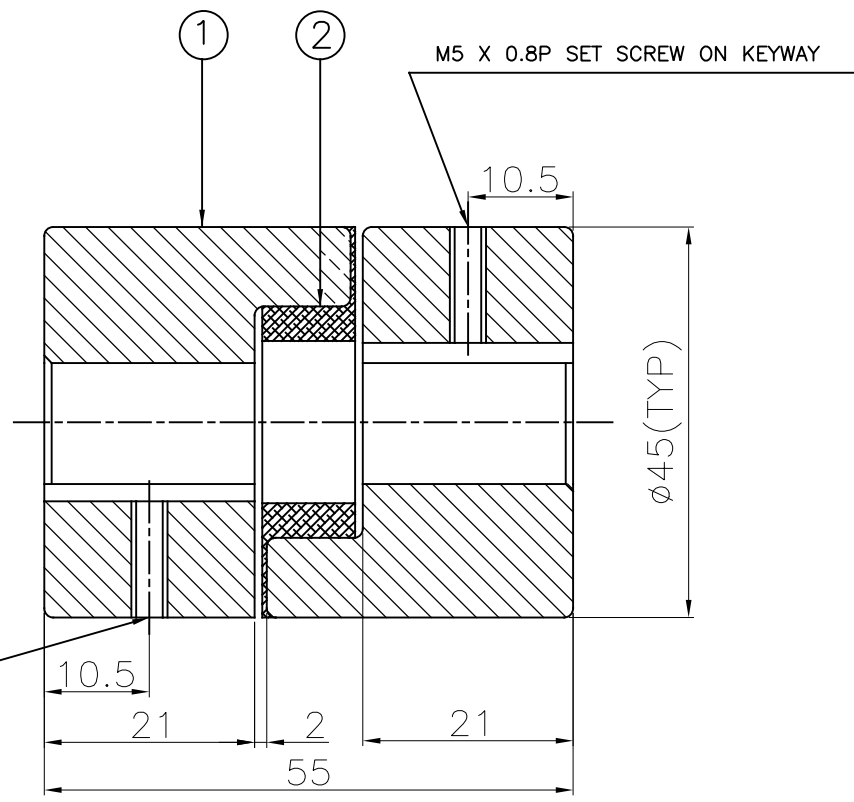
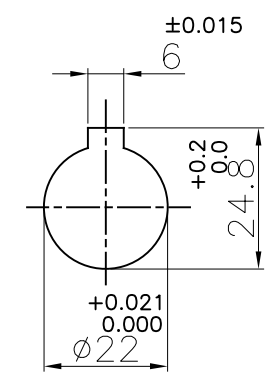

M5 X 0.8P SET SCREW ON KEYWAY

M5 X 0.8P SET SCREW ON KEYWAY

APPLICATION DETAILS

APPLICATION	-
RATED POWER	- KW
RATED SPEED	- RPM
RATED TORQUE	- Nm
A.S.F.	-

COUPLING SPECIFICATIONS

COUPLING RATING	0.1 KW AT 100 RPM
RATED TORQUE	9.80 Nm
MAX. BORE	22 mm
WEIGHT (Approx.)	0.44 Kg
INERTIA (WK ²)	1.19X10 ⁻⁵ Kgm ²

CPLG HUBS DYNAMICALLY BALANCED TO GR.6.3 AS PER ISO 1940- 1.

MAX. MISALIGNMENTS

AXIAL DEFLECTION	±1 mm
ANGULAR DEFLECTION	1°
RADIAL DEFLECTION	0.4 mm

2	SPIDER	NITRILE RUBBER	1
1	HUB	SINTERED IRON	2
SR NO	DESCRIPTION	MATERIAL	QTY.

REV.	DMRN NO.	DESCRIPTION	REV. BY	DATE

TITLE: **L-75/----- CPLG** MATERIAL: **REFER TABLE**

AUTHORITY: _____ INITIALS: _____ SIGN: _____ DATE: _____

CHECKED: _____

APPROVED: _____

CUSTOMER NAME: _____

SCALE: NTS REF. No.: _____

RATHI RATHI TRANSPOWER PVT LTD PUNE 411014 DRG. No.: _____

This drawing / information / design is the property of Rathi Transpower Pvt. Ltd. It is confidential & must not be made public or copied without prior written authorization & is subjected to recall at any time. Acceptance of this drawing constitutes full agreement with these conditions